

2-Bedroom

Type B1-G 60 SQM / 646 SQFT
INCLUSIVE OF 5 SQM PES

TOWER	UNIT
54	#01-08
56	#01-11*
58	#01-28*
60	#01-38*
62	#01-46
64	#01-55

Type B1 60 SQM / 646 SQFT
INCLUSIVE OF 5 SQM BALCONY

TOWER	UNIT
54	#02-08 TO #05-08
56	#02-11* TO #05-11*
58	#02-28* TO #05-28*
60	#02-38* TO #05-38*
62	#02-46 TO #05-46
64	#02-55 TO #05-55

Legend (where applicable):

- F - Fridge
- P - Pantry
- O - Oven
- GH - Gas Hob
- *Mirror Image
- IH - Induction Hob
- WD - Washer Dryer
- DB - Distribution Board
- ST - Store

ALL PLANS ARE SUBJECT TO AMENDMENTS AS MAY BE APPROVED BY THE RELEVANT AUTHORITIES.
FLOOR AREAS ARE APPROXIMATE MEASUREMENTS AND ARE SUBJECT TO FINAL SURVEY.

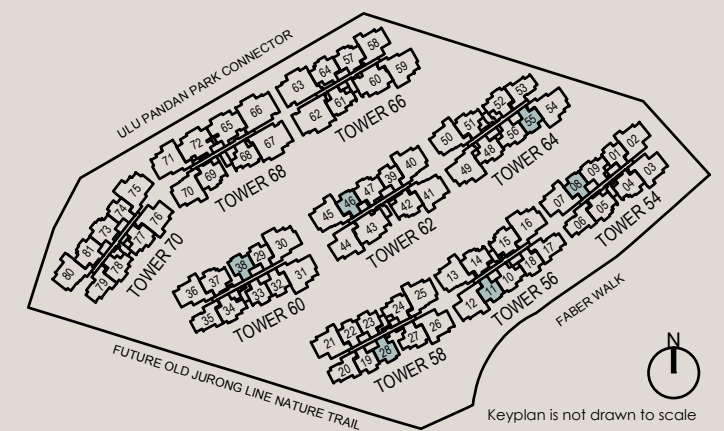
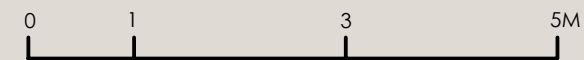
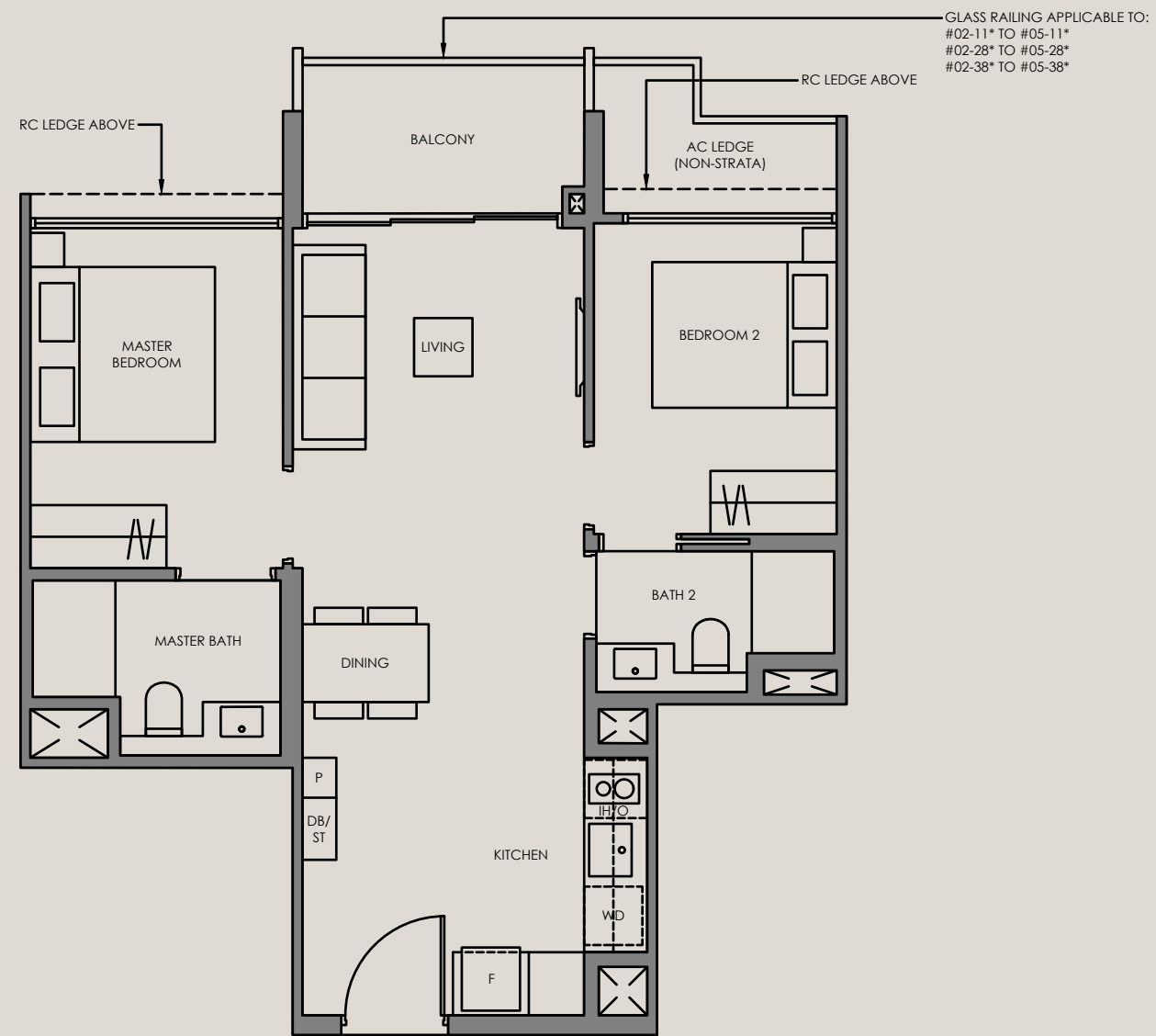
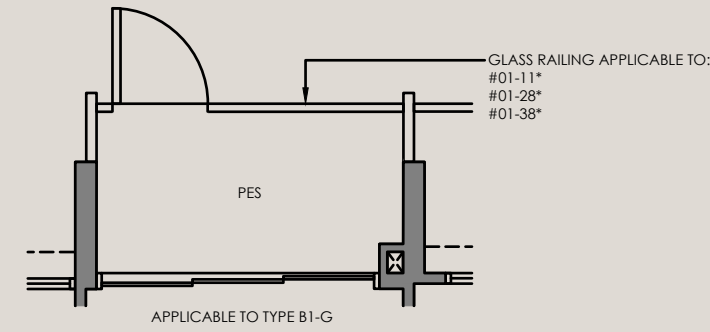

2-Bedroom

Type B2-G 60 SQM / 646 SQFT
INCLUSIVE OF 5 SQM PES

TOWER	UNIT
58	#01-23
60	#01-33

Type B2 60 SQM / 646 SQFT
INCLUSIVE OF 5 SQM BALCONY

TOWER	UNIT
58	#02-23 TO #05-23
60	#02-33 TO #05-33

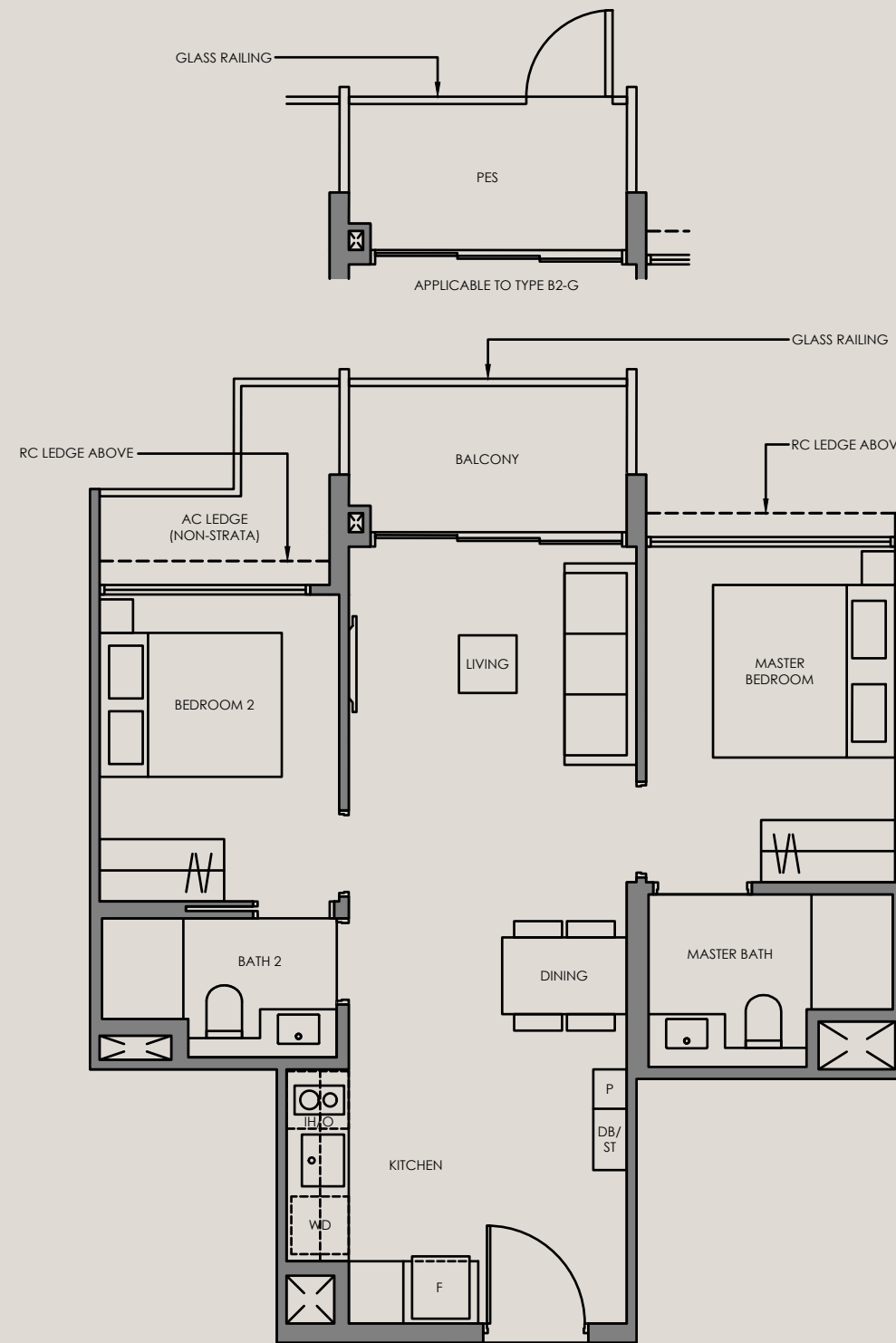

Legend (where applicable):

- F - Fridge
- P - Pantry
- O - Oven
- GH - Gas Hob
- *Mirror Image
- IH - Induction Hob
- WD - Washer Dryer
- DB - Distribution Board
- ST - Store

ALL PLANS ARE SUBJECT TO AMENDMENTS AS MAY BE APPROVED BY THE RELEVANT AUTHORITIES. FLOOR AREAS ARE APPROXIMATE MEASUREMENTS AND ARE SUBJECT TO FINAL SURVEY.

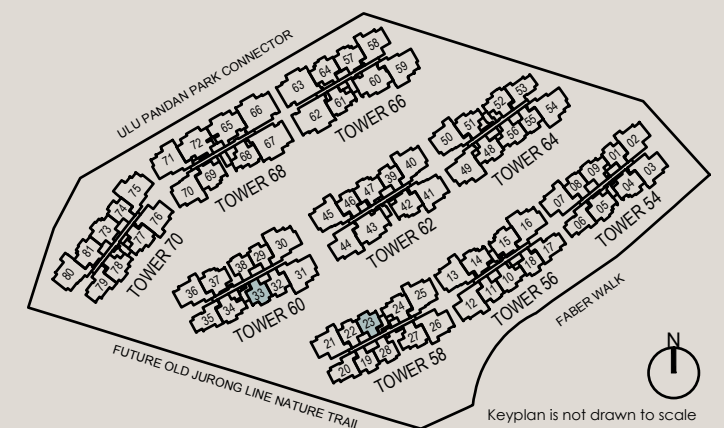
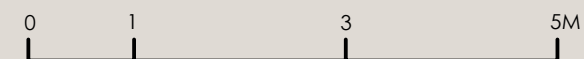

2-Bedroom

Type B3-G 60 SQM / 646 SQFT
INCLUSIVE OF 5 SQM PES

TOWER	UNIT
54	#01-01*
56	#01-18
58	#01-19* #01-22
60	#01-29* #01-32
62	#01-39*
70	#01-74*

Type B3 60 SQM / 646 SQFT
INCLUSIVE OF 5 SQM BALCONY

TOWER	UNIT
54	#02-01* TO #05-01*
56	#02-18 TO #05-18
58	#02-19* TO #05-19* #02-22 TO #05-22
60	#02-29* TO #05-29* #02-32 TO #05-32
62	#02-39* TO #05-39*
70	#02-74* TO #05-74*



Legend (where applicable):

- F - Fridge
- P - Pantry
- O - Oven
- GH - Gas Hob
- *Mirror Image
- IH - Induction Hob
- WD - Washer Dryer
- DB - Distribution Board
- ST - Store

ALL PLANS ARE SUBJECT TO AMENDMENTS AS MAY BE APPROVED BY THE RELEVANT AUTHORITIES.
FLOOR AREAS ARE APPROXIMATE MEASUREMENTS AND ARE SUBJECT TO FINAL SURVEY.

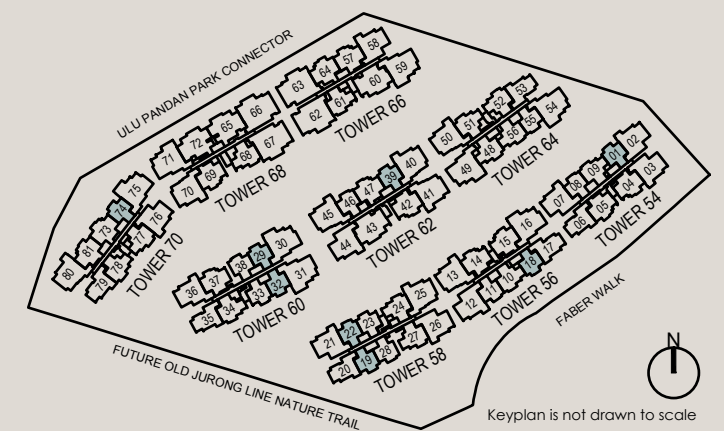
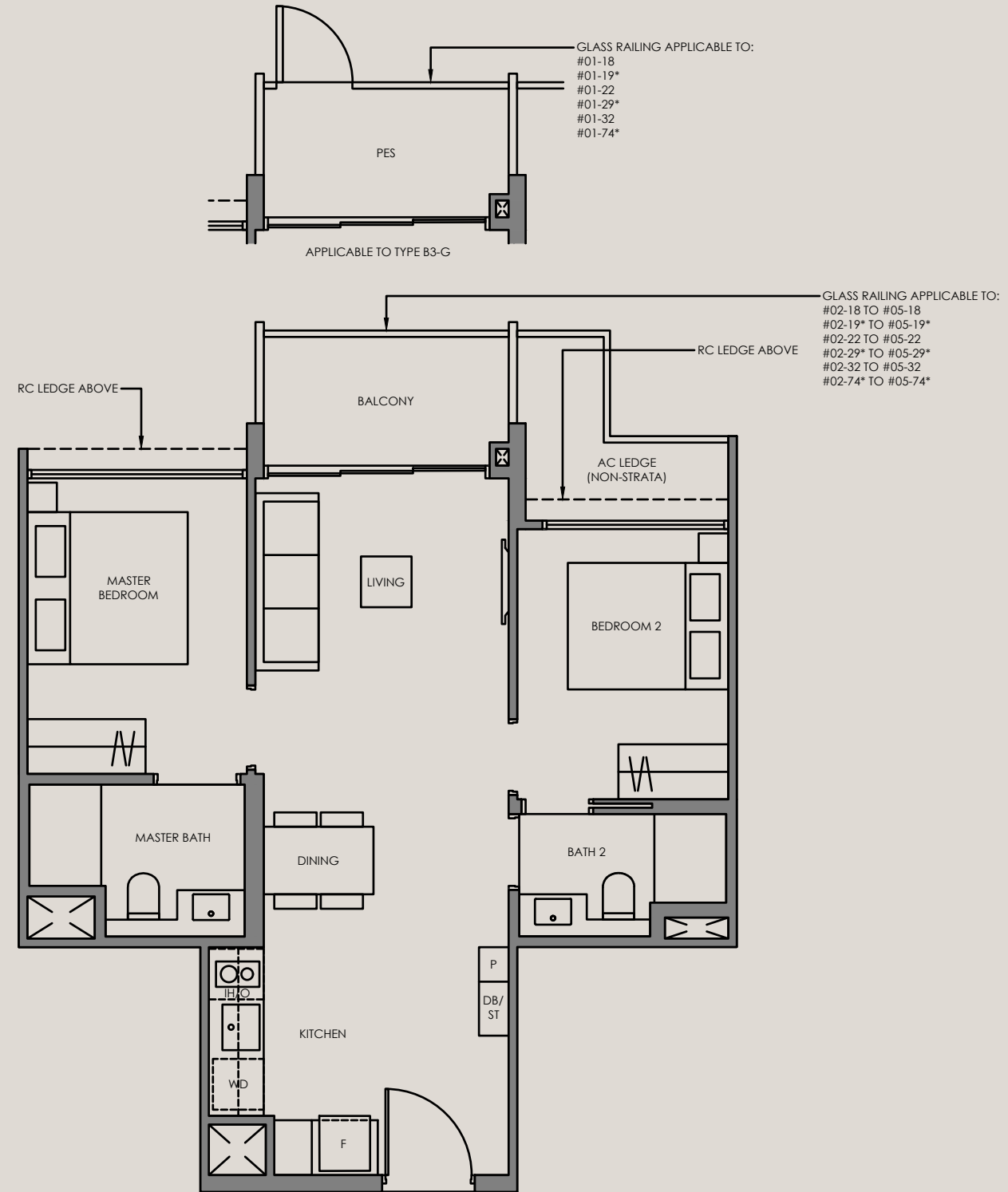

Keyplan is not drawn to scale

3-Bedroom

Type C1-G 74 SQM / 797 SQFT
INCLUSIVE OF 5 SQM PES

TOWER	UNIT
58	#01-24
	#01-27*
	#01-34
60	#01-34
	#01-48*
64	#01-48*
	#01-51*
	#01-52
70	#01-77*
	#01-78
	#01-78

Type C1 74 SQM / 797 SQFT
INCLUSIVE OF 5 SQM BALCONY

TOWER	UNIT
58	#02-24 TO #05-24
	#02-27* TO #05-27*
60	#02-34 TO #05-34
64	#02-48* TO #05-48*
	#02-51* TO #05-51*
	#02-52 TO #05-52
	#02-77* TO #05-77*
70	#02-77* TO #05-77*
	#02-78 TO #05-78



Legend (where applicable):

- F - Fridge
- P - Pantry
- O - Oven
- GH - Gas Hob
- *Mirror Image
- IH - Induction Hob
- WD - Washer Dryer
- DB - Distribution Board
- ST - Store

ALL PLANS ARE SUBJECT TO AMENDMENTS AS MAY BE APPROVED BY THE RELEVANT AUTHORITIES. FLOOR AREAS ARE APPROXIMATE MEASUREMENTS AND ARE SUBJECT TO FINAL SURVEY.

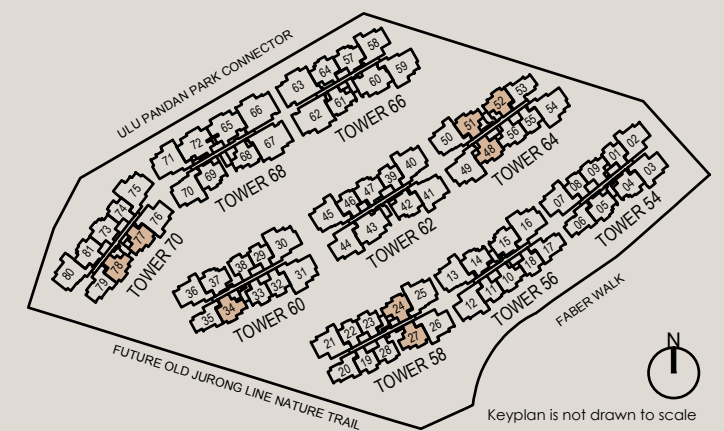
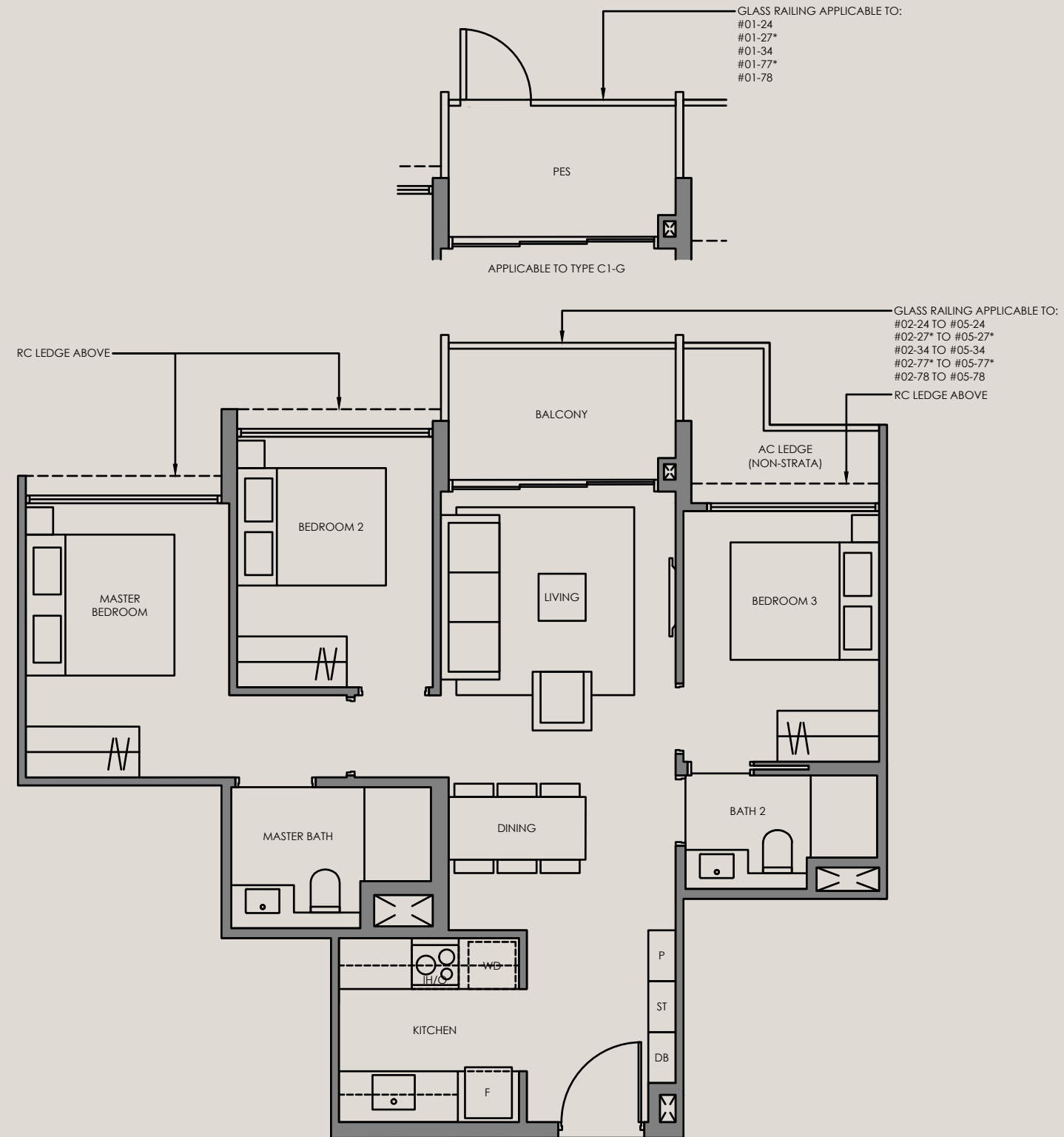

3-Bedroom

Type C2-G 74 SQM / 797 SQFT
INCLUSIVE OF 5 SQM PES

TOWER	UNIT
54	#01-09*
56	#01-10
64	#01-56*
66	#01-61
68	#01-68*

Type C2 74 SQM / 797 SQFT
INCLUSIVE OF 5 SQM BALCONY

TOWER	UNIT
54	#02-09* TO #05-09*
56	#02-10 TO #05-10
64	#02-56* TO #05-56*
66	#02-61 TO #05-61
68	#02-68* TO #05-68*

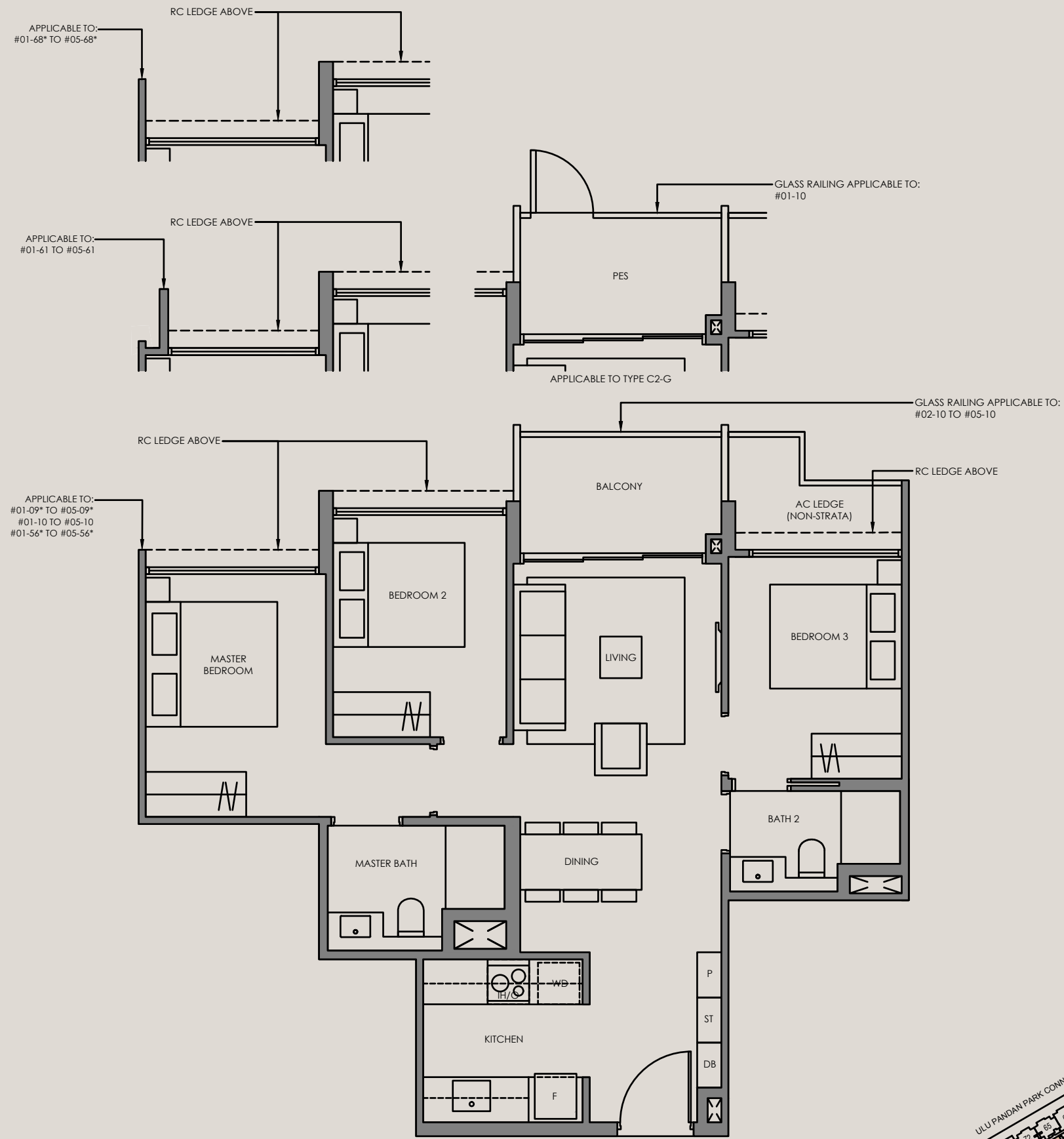

Legend (where applicable):

- F - Fridge
- IH - Induction Hob
- P - Pantry
- WD - Washer Dryer
- O - Oven
- DB - Distribution Board
- GH - Gas Hob
- ST - Store

*Mirror Image

ALL PLANS ARE SUBJECT TO AMENDMENTS AS MAY BE APPROVED BY THE RELEVANT AUTHORITIES. FLOOR AREAS ARE APPROXIMATE MEASUREMENTS AND ARE SUBJECT TO FINAL SURVEY.

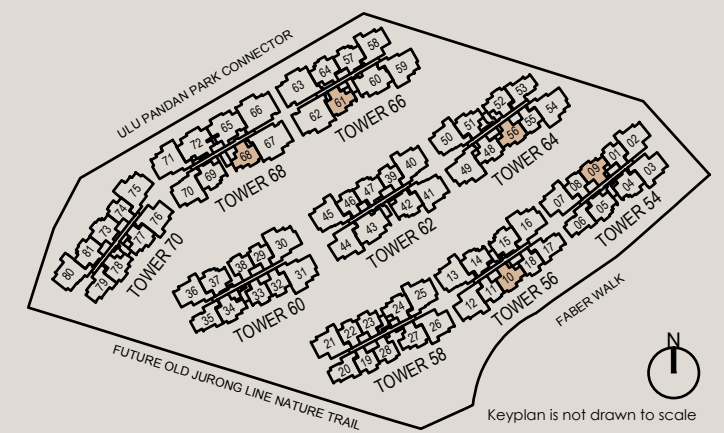

3-Bedroom

Type C3-G 76 SQM / 818 SQFT
INCLUSIVE OF 5 SQM PES

TOWER	UNIT
58	#01-20
64	#01-53
70	#01-79

Type C3 76 SQM / 818 SQFT
INCLUSIVE OF 5 SQM BALCONY

TOWER	UNIT
54	#03-06 TO #05-06
58	#02-20 TO #05-20
64	#02-53 TO #05-53
70	#02-79 TO #05-79

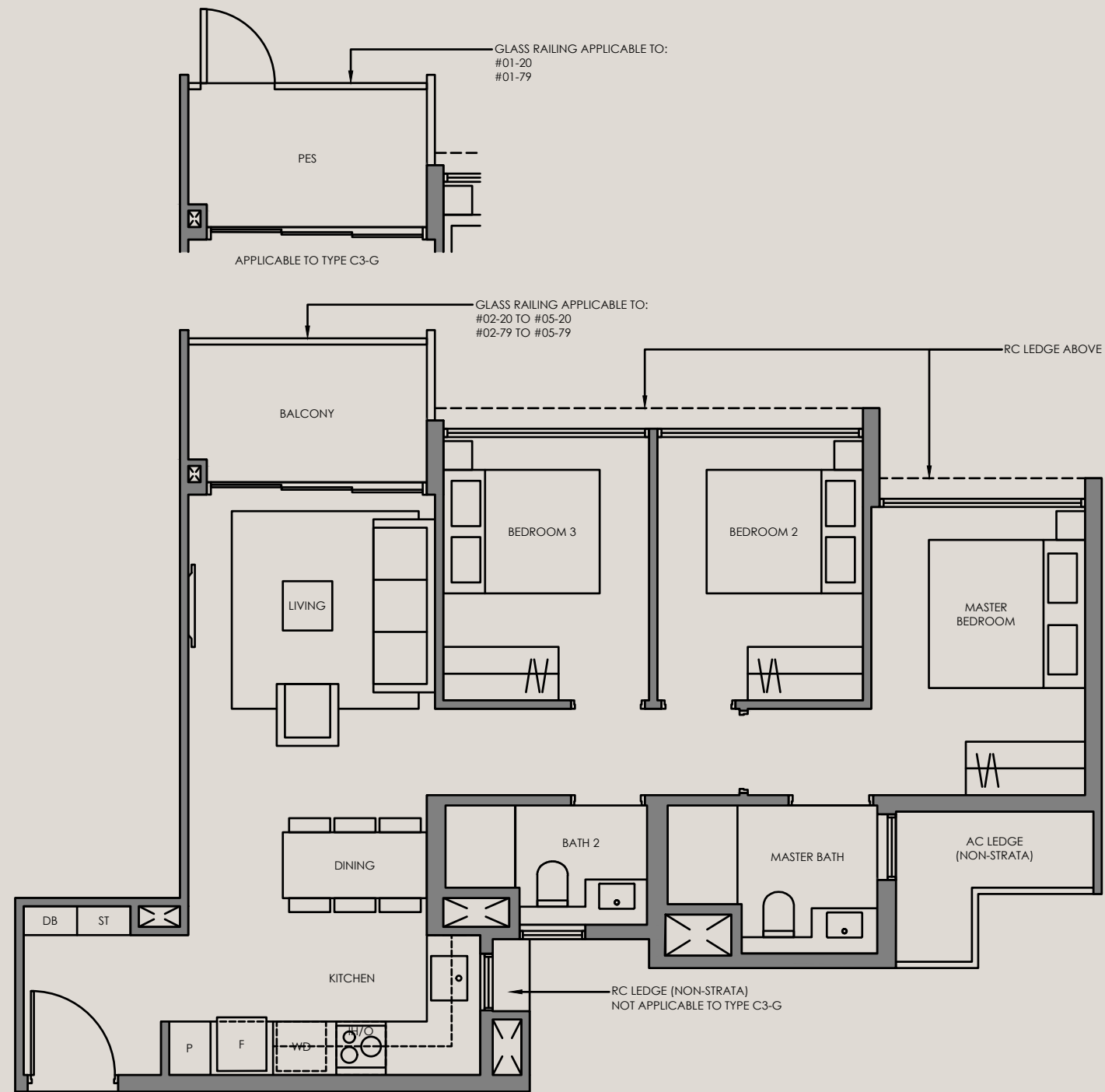

Legend (where applicable):

- F - Fridge
- P - Pantry
- O - Oven
- GH - Gas Hob
- IH - Induction Hob
- WD - Washer Dryer
- DB - Distribution Board
- ST - Store

*Mirror Image

ALL PLANS ARE SUBJECTED TO AMENDMENTS AS MAY BE APPROVED BY THE RELEVANT AUTHORITIES.
FLOOR AREAS ARE APPROXIMATE MEASUREMENTS AND ARE SUBJECTED TO FINAL SURVEY.

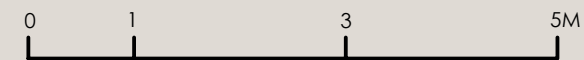
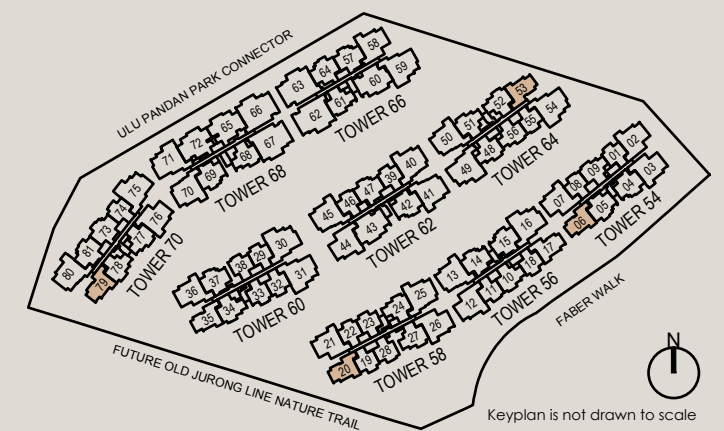

3-Bedroom

Type C4-G 76 SQM / 818 SQFT
INCLUSIVE OF 5 SQM PES

TOWER	UNIT
56	#01-17*
60	#01-35

Type C4 76 SQM / 818 SQFT
INCLUSIVE OF 5 SQM BALCONY

TOWER	UNIT
56	#02-17* TO #05-17*
60	#02-35 TO #05-35

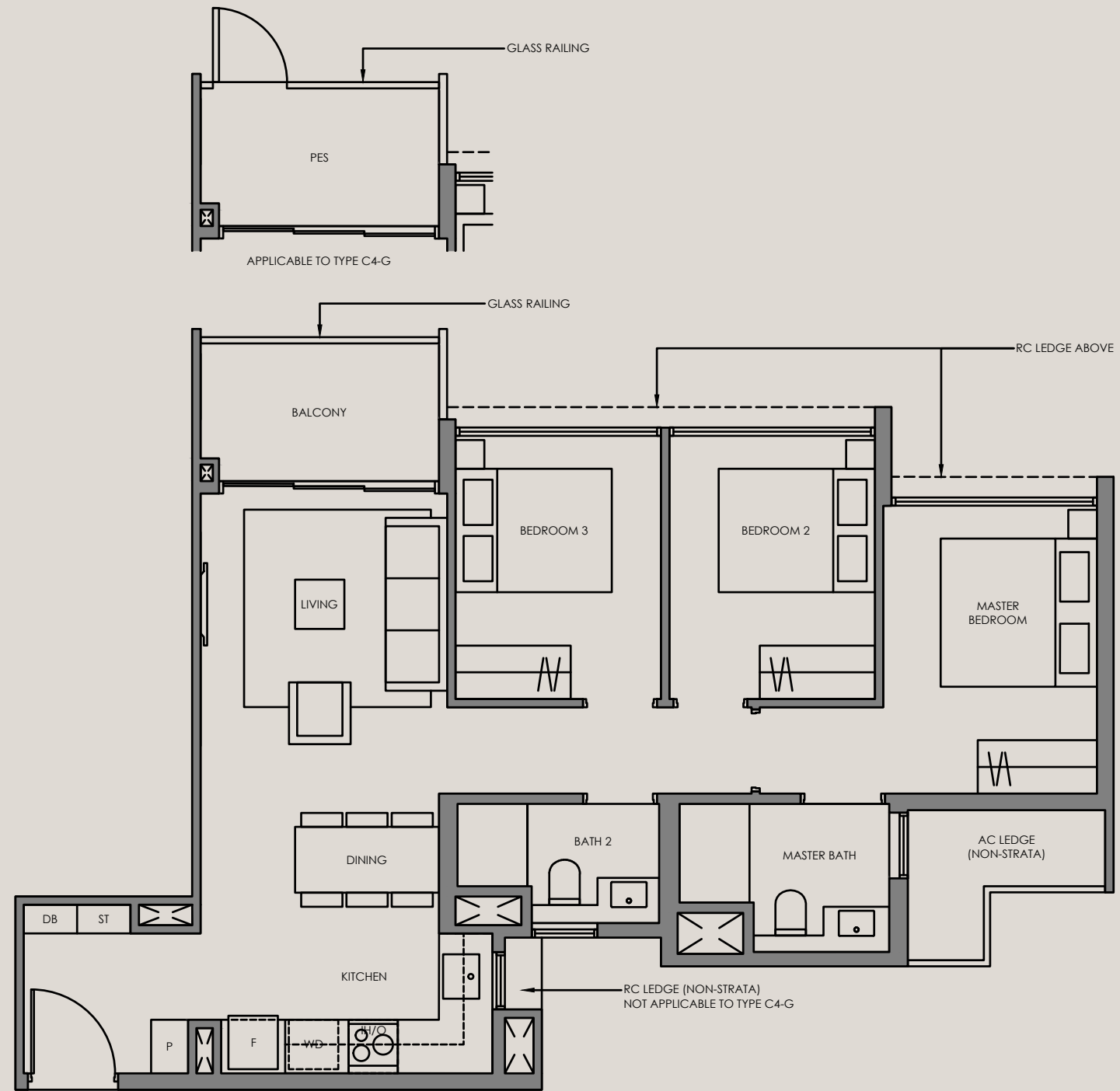

Legend (where applicable):

- F - Fridge
- P - Pantry
- O - Oven
- GH - Gas Hob
- IH - Induction Hob
- WD - Washer Dryer
- DB - Distribution Board
- ST - Store

*Mirror Image

ALL PLANS ARE SUBJECT TO AMENDMENTS AS MAY BE APPROVED BY THE RELEVANT AUTHORITIES.
FLOOR AREAS ARE APPROXIMATE MEASUREMENTS AND ARE SUBJECT TO FINAL SURVEY.

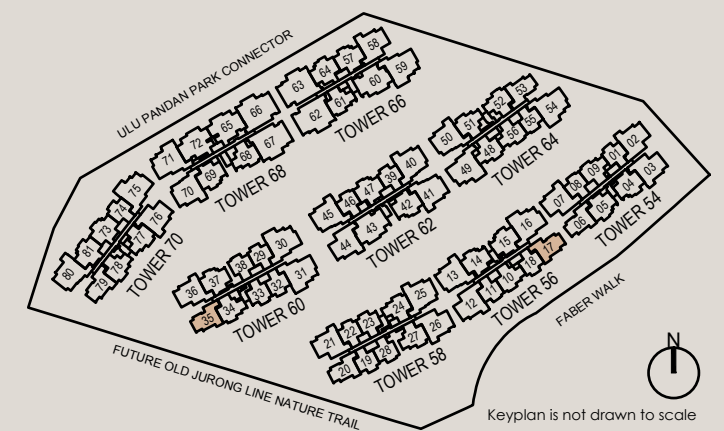
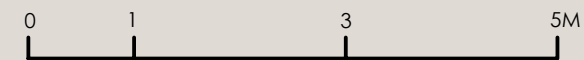

Keyplan is not drawn to scale

3-Bedroom

Type C5-G 80 SQM / 861 SQFT
INCLUSIVE OF 6 SQM PES

TOWER	UNIT
56	#01-14 #01-15*
60	#01-37
62	#01-42
66	#01-57
68	#01-69*
70	#01-81*

Type C5 80 SQM / 861 SQFT
INCLUSIVE OF 6 SQM BALCONY

TOWER	UNIT
54	#03-04 TO #05-04 #03-05* TO #05-05*
56	#02-14 TO #05-14 #02-15* TO #05-15*
60	#02-37 TO #05-37
62	#02-42 TO #05-42
66	#02-57 TO #05-57
68	#02-69* TO #05-69*
70	#02-81* TO #05-81*

Legend (where applicable):

- F - Fridge
- IH - Induction Hob
- P - Pantry
- WD - Washer Dryer
- O - Oven
- DB - Distribution Board
- GH - Gas Hob
- ST - Store

*Mirror Image

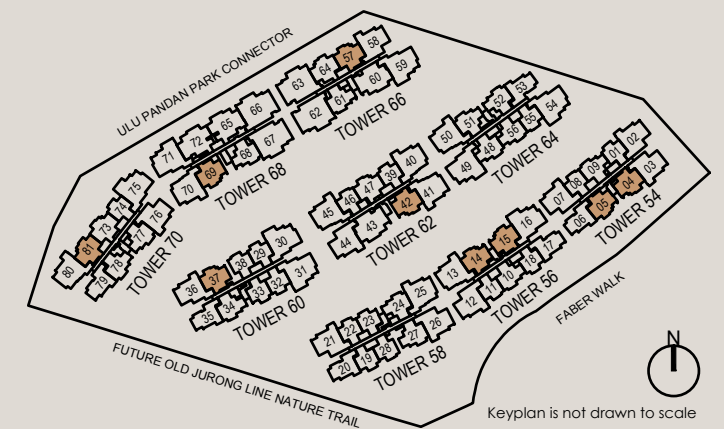
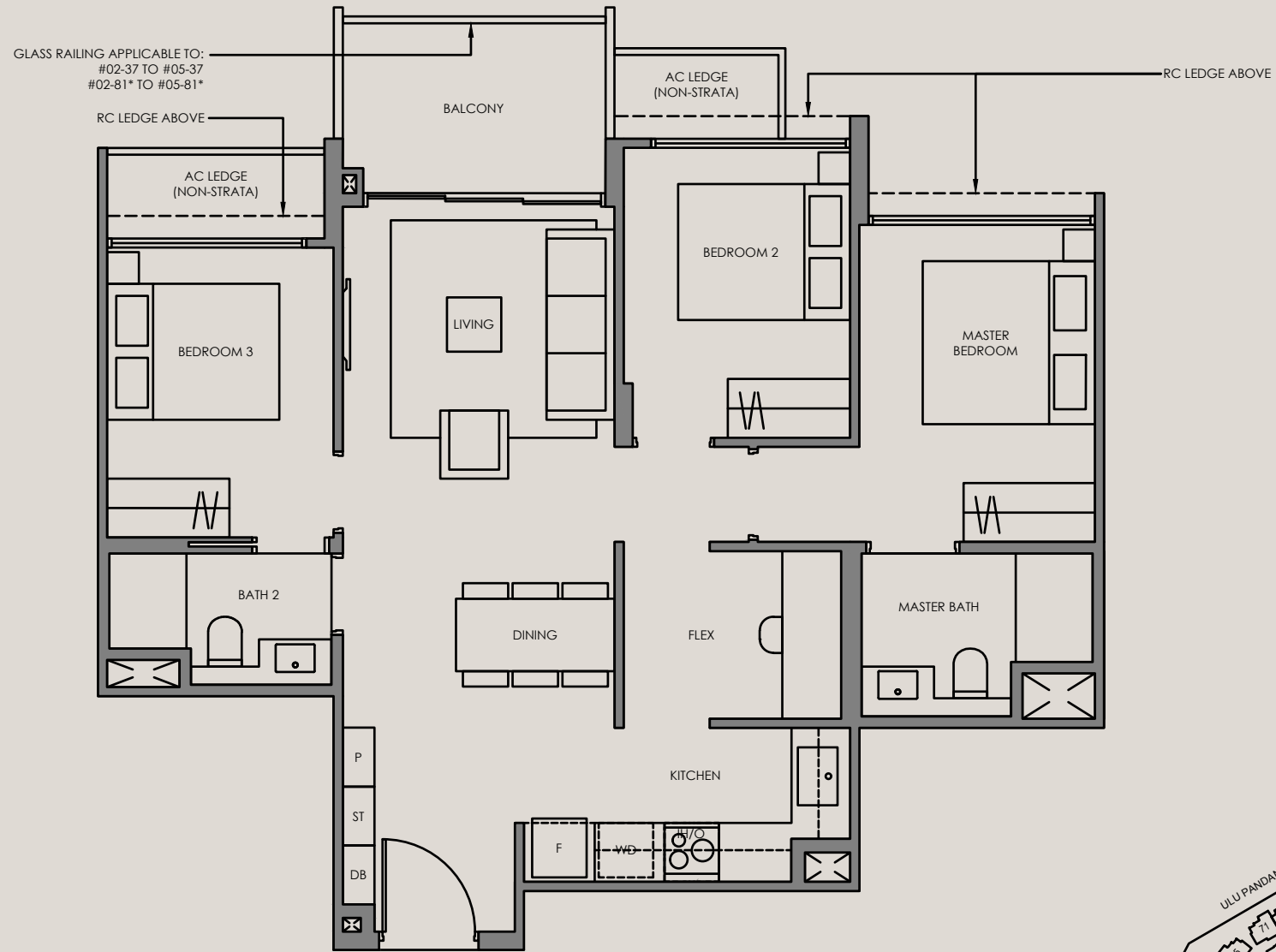
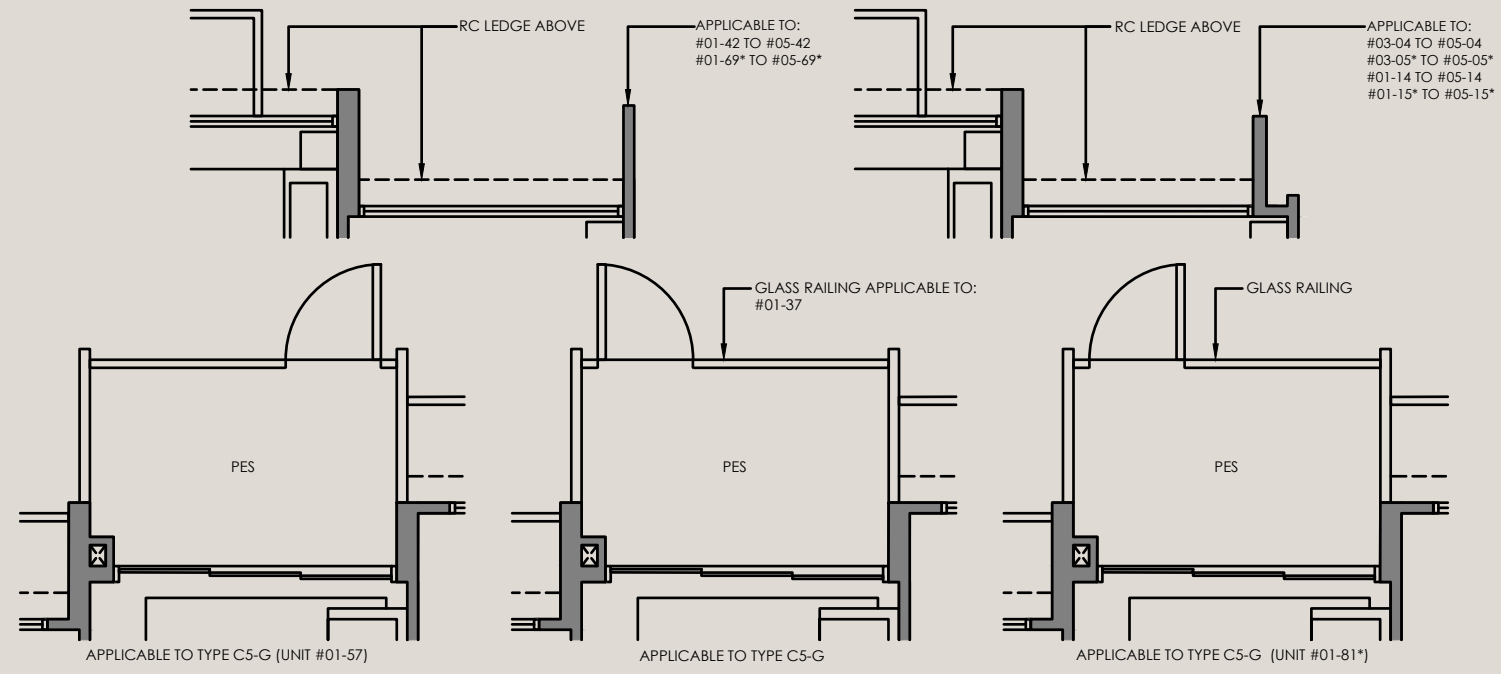

3-Bedroom

Type C6-G 80 SQM / 861 SQFT
INCLUSIVE OF 6 SQM PES

TOWER	UNIT
62	#01-47
70	#01-73

Type C6 80 SQM / 861 SQFT
INCLUSIVE OF 6 SQM BALCONY

TOWER	UNIT
62	#02-47 TO #05-47
70	#02-73 TO #05-73

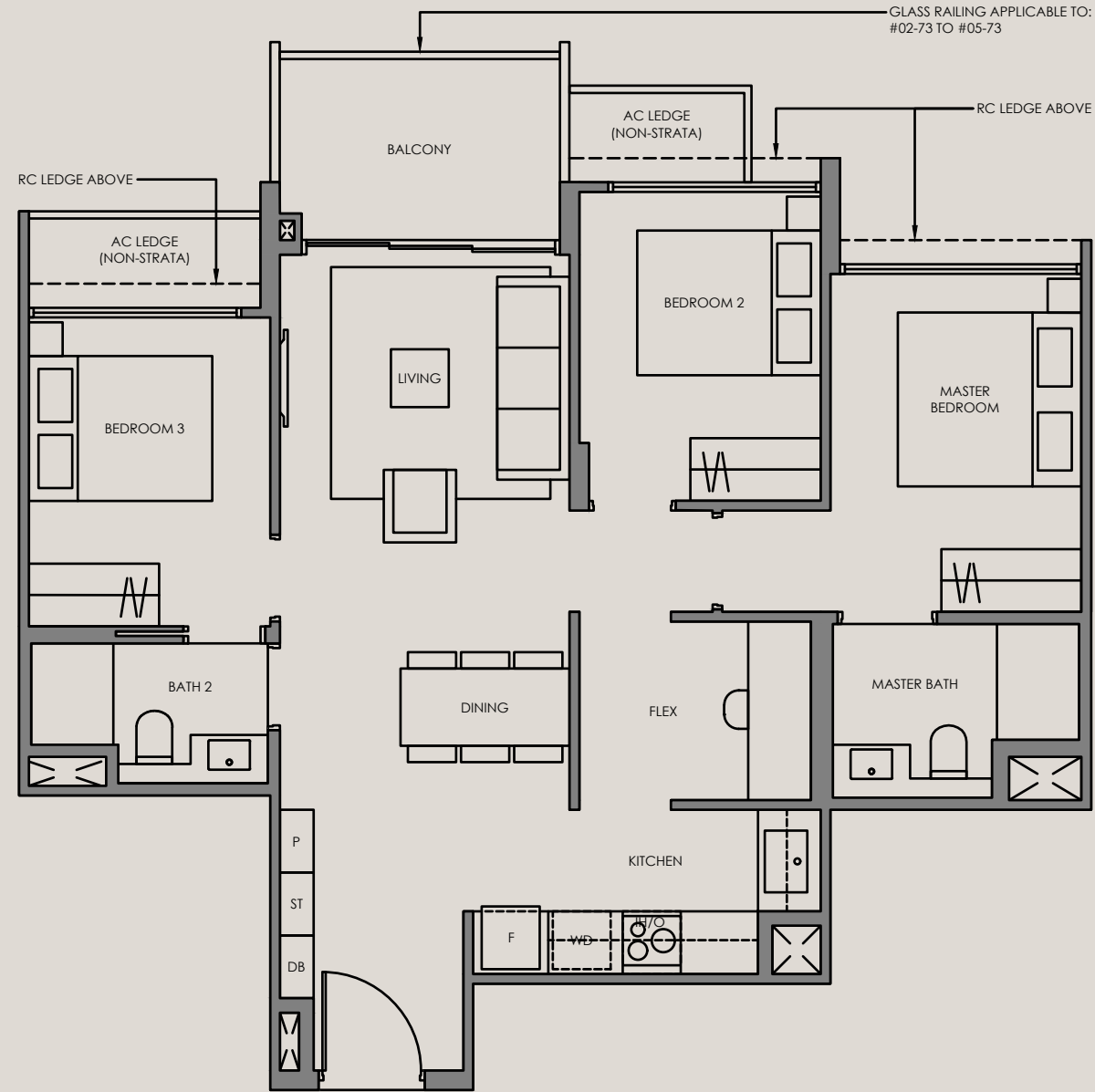
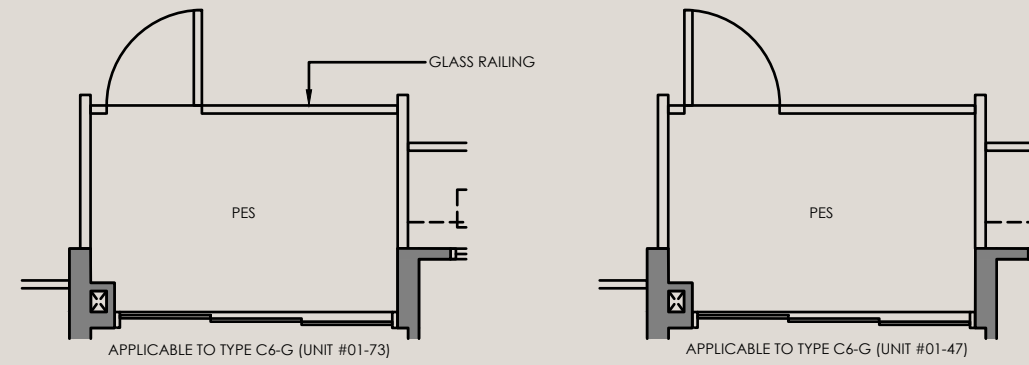

Legend (where applicable):

- F - Fridge
- P - Pantry
- O - Oven
- GH - Gas Hob
- IH - Induction Hob
- WD - Washer Dryer
- DB - Distribution Board
- ST - Store

*Mirror Image

ALL PLANS ARE SUBJECT TO AMENDMENTS AS MAY BE APPROVED BY THE RELEVANT AUTHORITIES. FLOOR AREAS ARE APPROXIMATE MEASUREMENTS AND ARE SUBJECT TO FINAL SURVEY.

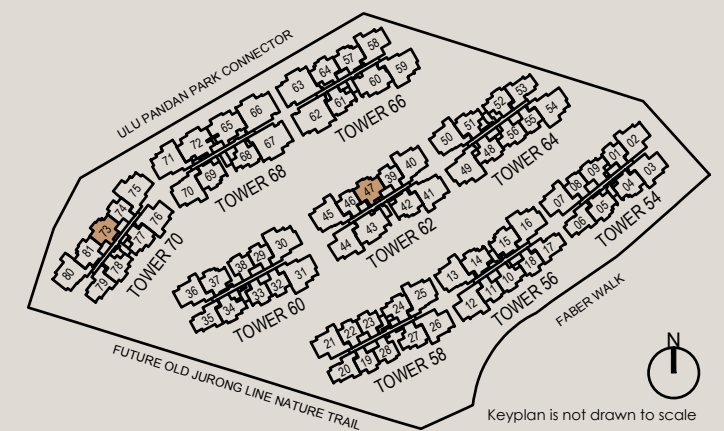

Keyplan is not drawn to scale

3-Bedroom

Type C7-G 80 SQM / 861 SQFT
INCLUSIVE OF 6 SQM PES

TOWER 66
UNIT #01-64

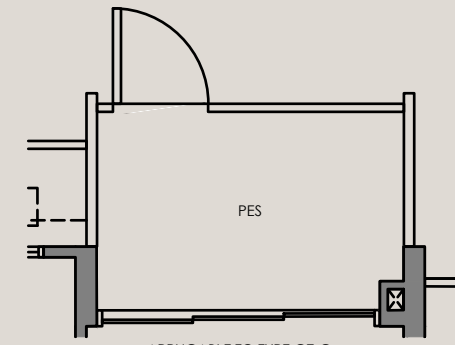

APPLICABLE TO TYPE C7-G

Type C7 80 SQM / 861 SQFT
INCLUSIVE OF 6 SQM BALCONY

TOWER 66
UNIT #02-64 TO #05-64

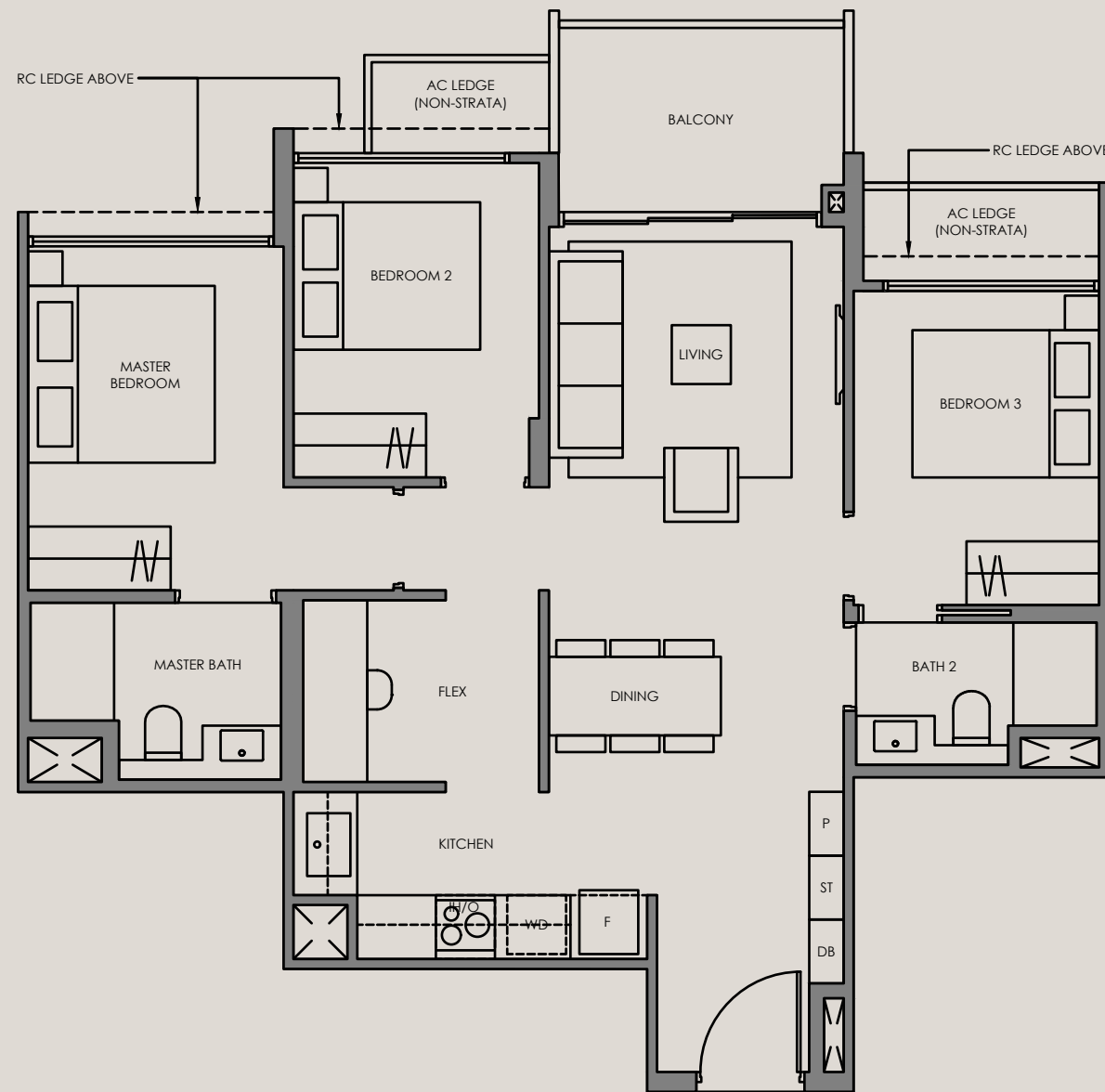

Legend (where applicable):

- F - Fridge
- P - Pantry
- O - Oven
- GH - Gas Hob
- IH - Induction Hob
- WD - Washer Dryer
- DB - Distribution Board
- ST - Store

*Mirror Image

ALL PLANS ARE SUBJECT TO AMENDMENTS AS MAY BE APPROVED BY THE RELEVANT AUTHORITIES.
FLOOR AREAS ARE APPROXIMATE MEASUREMENTS AND ARE SUBJECT TO FINAL SURVEY.

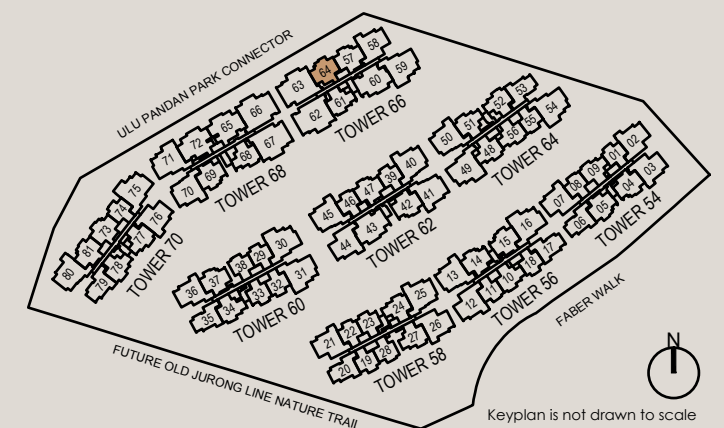
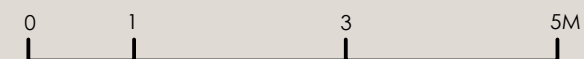

3-Bedroom

Type C8-G 96 SQM / 1033 SQFT
INCLUSIVE OF 6 SQM PES

TOWER 62
UNIT #01-44

Type C8 96 SQM / 1033 SQFT
INCLUSIVE OF 6 SQM BALCONY

TOWER 62
UNIT #02-44 TO #05-44

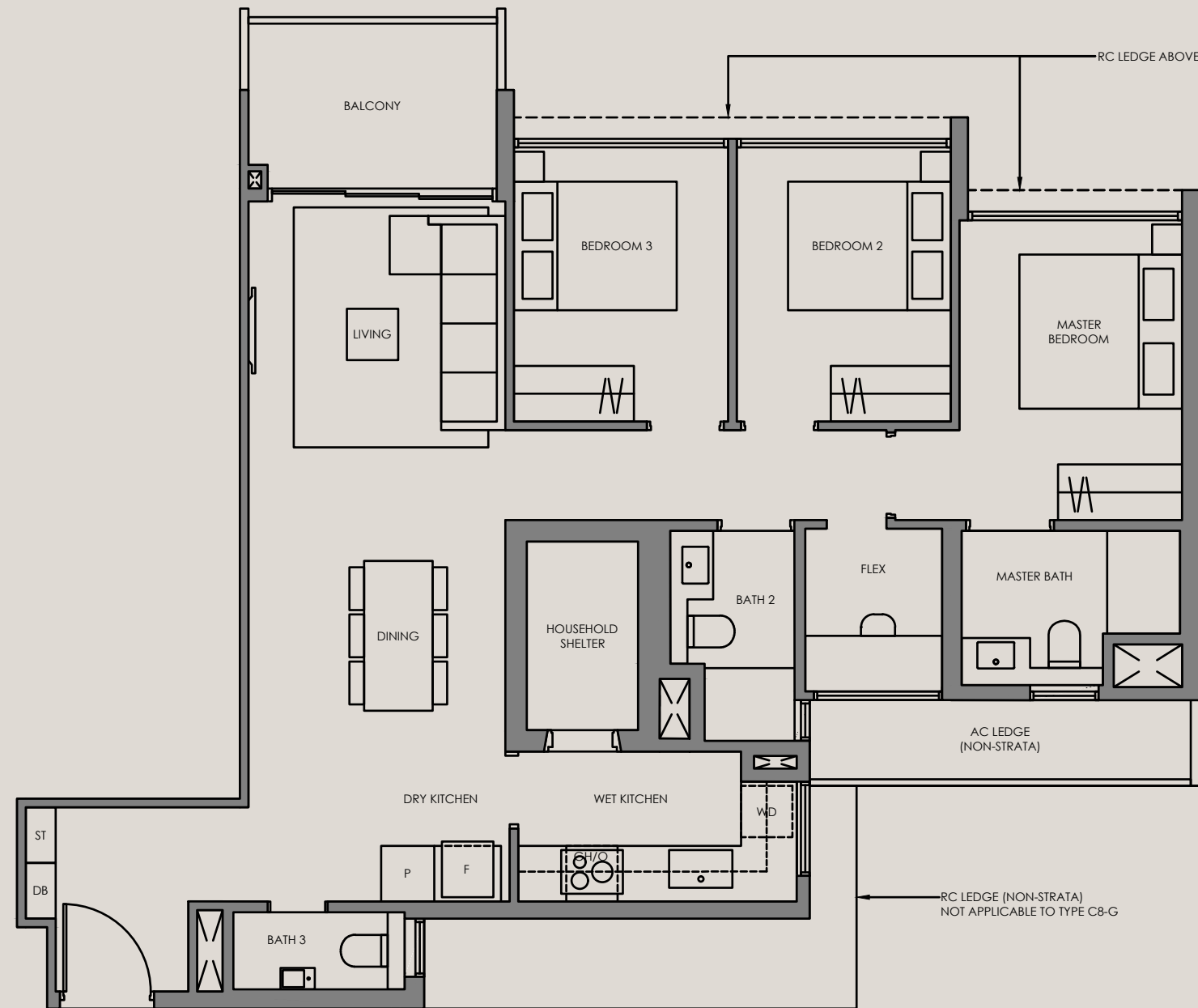
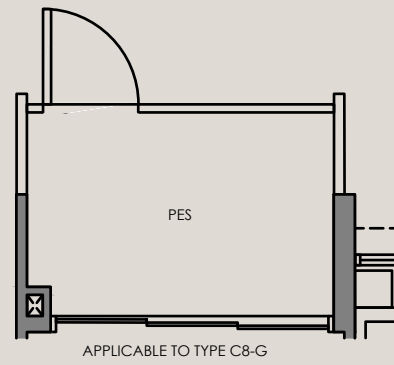

Legend (where applicable):

- F - Fridge
- P - Pantry
- O - Oven
- GH - Gas Hob
- IH - Induction Hob
- WD - Washer Dryer
- DB - Distribution Board
- ST - Store

*Mirror Image

ALL PLANS ARE SUBJECT TO AMENDMENTS AS MAY BE APPROVED BY THE RELEVANT AUTHORITIES.
FLOOR AREAS ARE APPROXIMATE MEASUREMENTS AND ARE SUBJECT TO FINAL SURVEY.

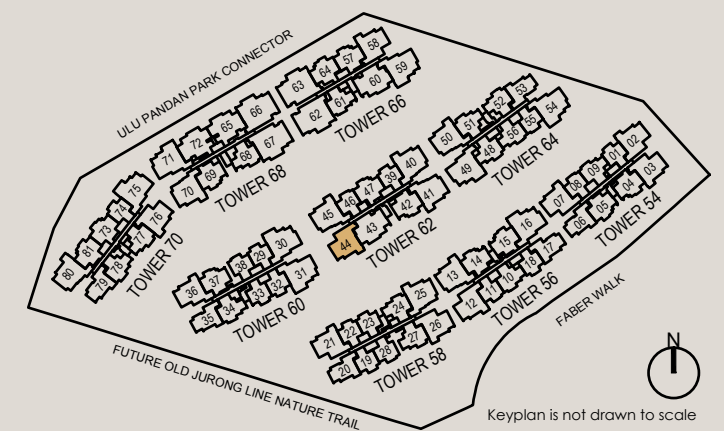

3-Bedroom

Type C9-G 96 SQM / 1033 SQFT
INCLUSIVE OF 6 SQM PES

TOWER	UNIT
54	#01-02
58	#01-21*

Type C9 96 SQM / 1033 SQFT
INCLUSIVE OF 6 SQM BALCONY

TOWER	UNIT
54	#02-02 TO #05-02
58	#02-21* TO #05-21*

Legend (where applicable):

- F - Fridge
- P - Pantry
- O - Oven
- GH - Gas Hob
- *Mirror Image
- IH - Induction Hob
- WD - Washer Dryer
- DB - Distribution Board
- ST - Store

ALL PLANS ARE SUBJECTED TO AMENDMENTS AS MAY BE APPROVED BY THE RELEVANT AUTHORITIES. FLOOR AREAS ARE APPROXIMATE MEASUREMENTS AND ARE SUBJECTED TO FINAL SURVEY.

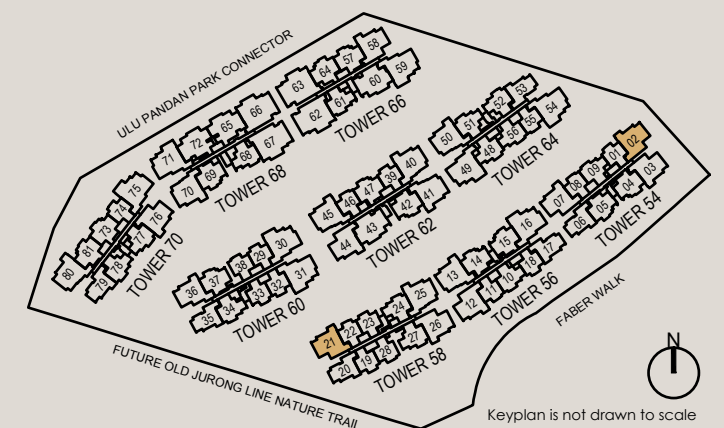
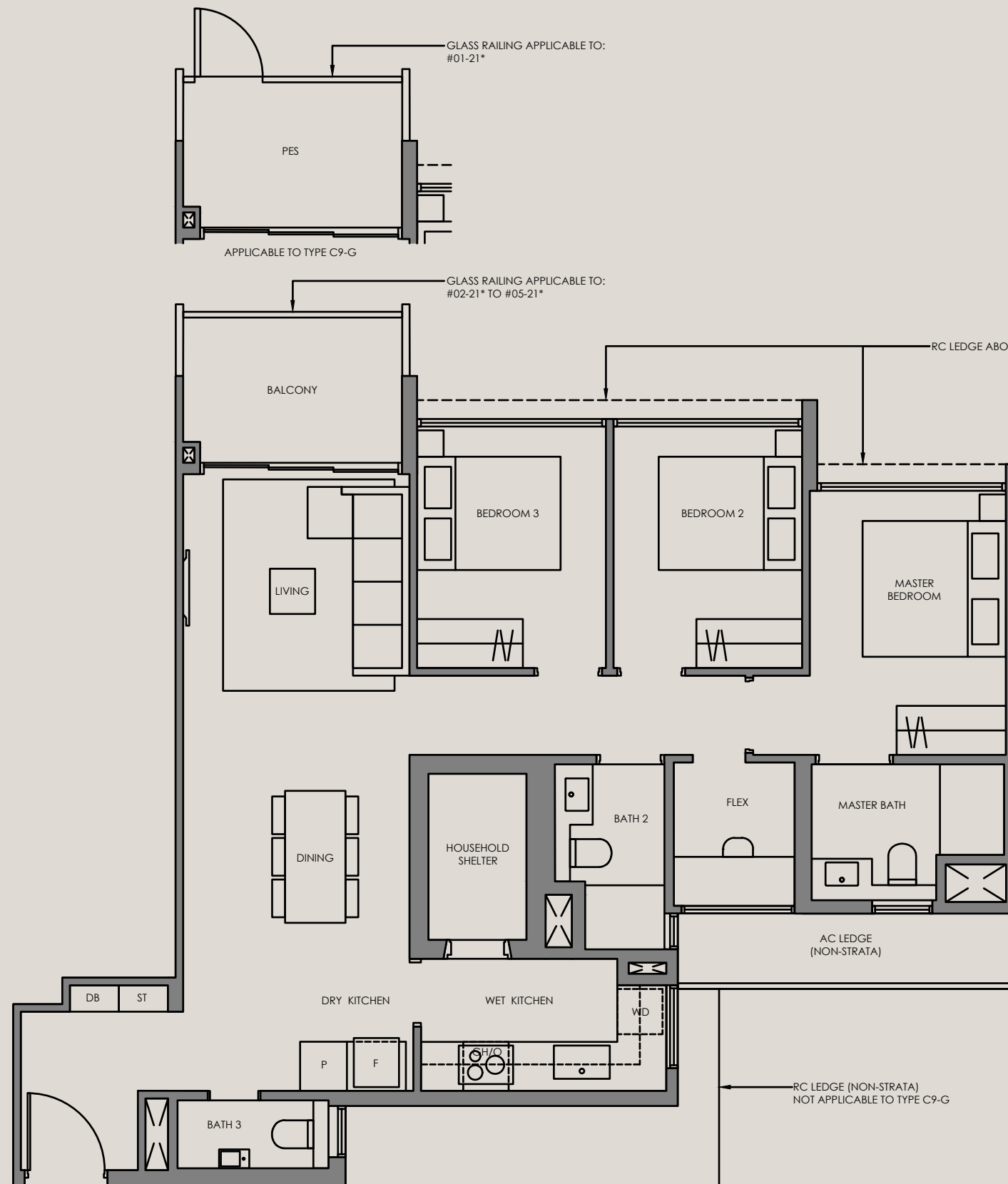

3-Bedroom

Type C10-G 96 SQM / 1033 SQFT
INCLUSIVE OF 6 SQM PES

TOWER	UNIT
54	#01-03*
66	#01-58
70	#01-76*

Type C10 96 SQM / 1033 SQFT
INCLUSIVE OF 6 SQM BALCONY

TOWER	UNIT
54	#02-03* TO #05-03*
66	#02-58 TO #05-58
70	#02-76* TO #05-76*

Legend (where applicable):

- F - Fridge
- P - Pantry
- O - Oven
- GH - Gas Hob
- IH - Induction Hob
- WD - Washer Dryer
- DB - Distribution Board
- ST - Store

*Mirror Image

ALL PLANS ARE SUBJECTED TO AMENDMENTS AS MAY BE APPROVED BY THE RELEVANT AUTHORITIES.
FLOOR AREAS ARE APPROXIMATE MEASUREMENTS AND ARE SUBJECTED TO FINAL SURVEY.

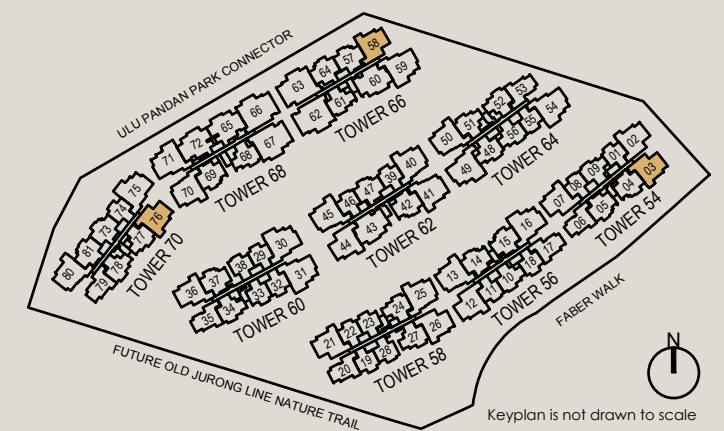
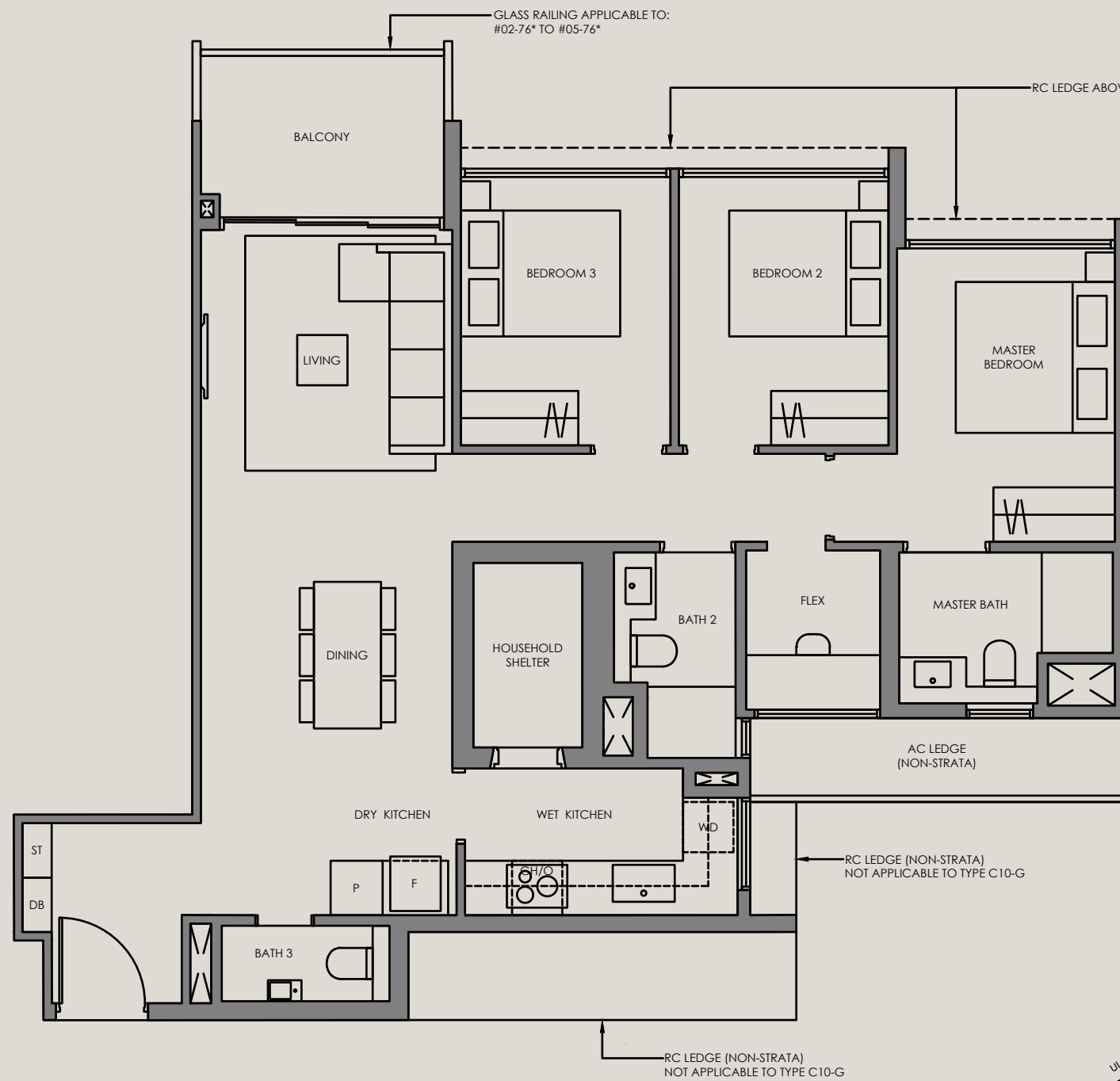
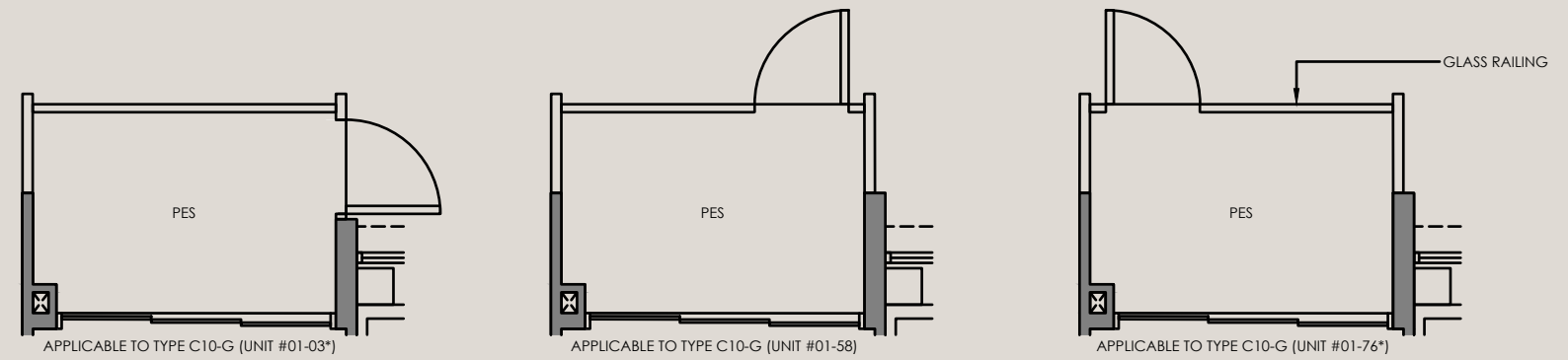

3-Bedroom

Type C11-G 97 SQM / 1044 SQFT
INCLUSIVE OF 6 SQM PES

TOWER	UNIT
54	#01-07*
56	#01-12
58	#01-26*
60	#01-36*

Type C11 97 SQM / 1044 SQFT
INCLUSIVE OF 6 SQM BALCONY

TOWER	UNIT
54	#02-07* TO #05-07*
56	#02-12 TO #05-12
58	#02-26* TO #05-26*
60	#02-36* TO #05-36*

 TAKE VIRTUAL TOUR

Legend (where applicable):

- F - Fridge
- P - Pantry
- O - Oven
- GH - Gas Hob
- IH - Induction Hob
- WD - Washer Dryer
- DB - Distribution Board
- ST - Store

*Mirror Image

ALL PLANS ARE SUBJECT TO AMENDMENTS AS MAY BE APPROVED BY THE RELEVANT AUTHORITIES.
FLOOR AREAS ARE APPROXIMATE MEASUREMENTS AND ARE SUBJECT TO FINAL SURVEY.

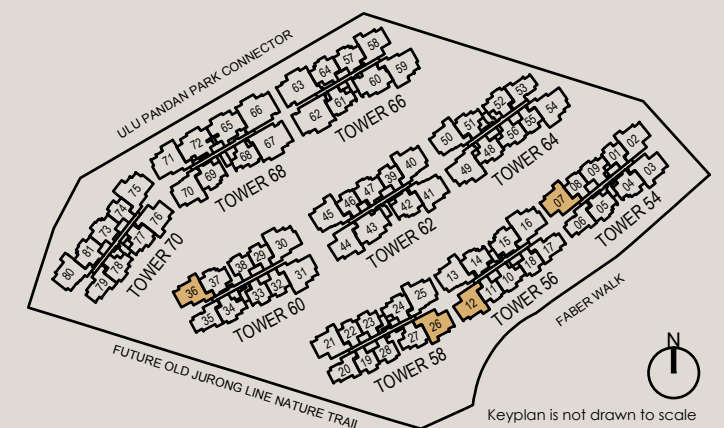
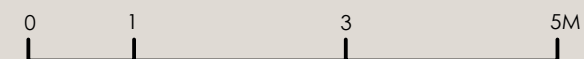
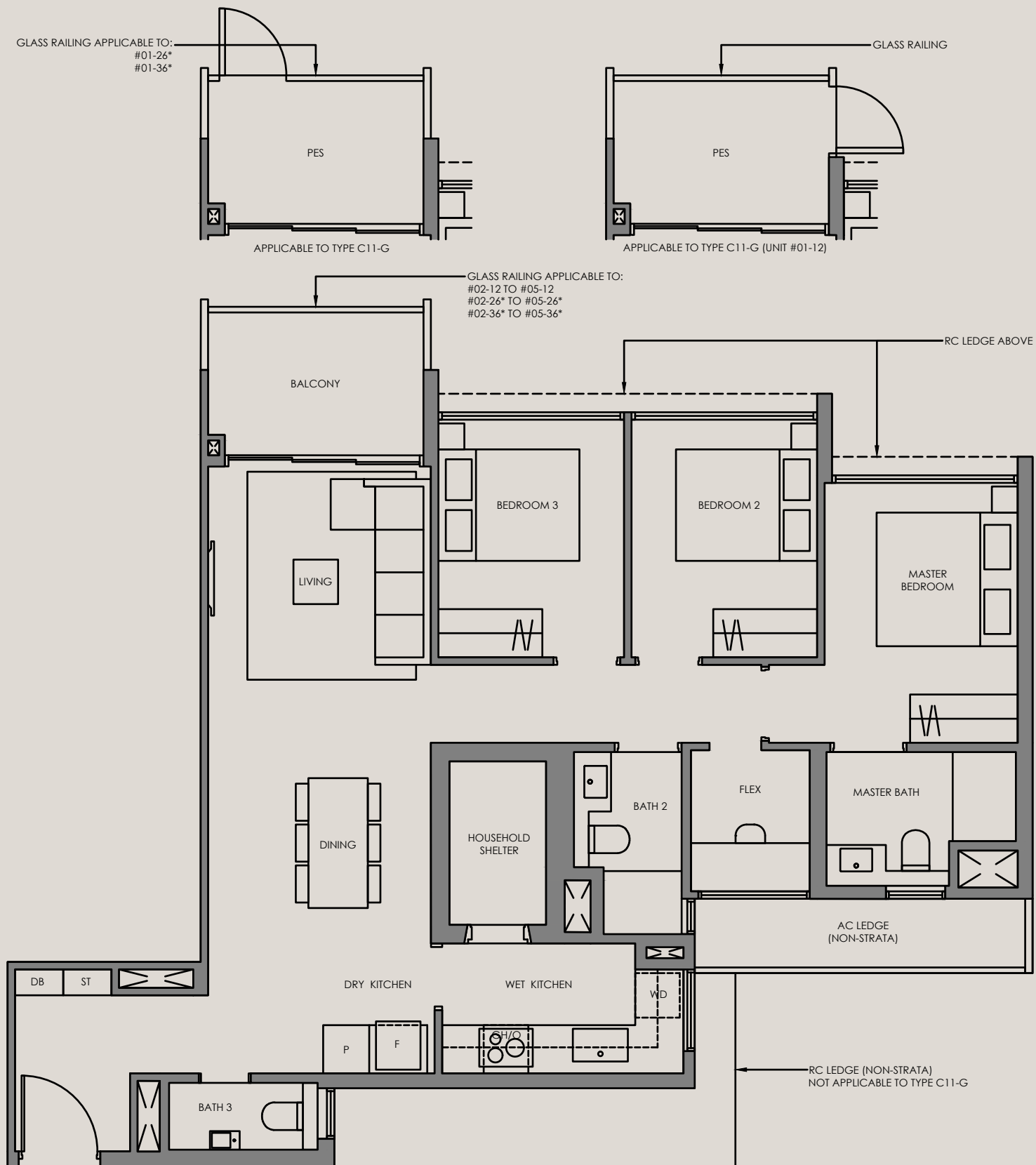

4-Bedroom

Type D1-G 104 SQM / 1119 SQFT
INCLUSIVE OF 6 SQM PES

TOWER 62
UNIT #01-40

Type D1 104 SQM / 1119 SQFT
INCLUSIVE OF 6 SQM BALCONY

TOWER 62
UNIT #02-40 TO #05-40

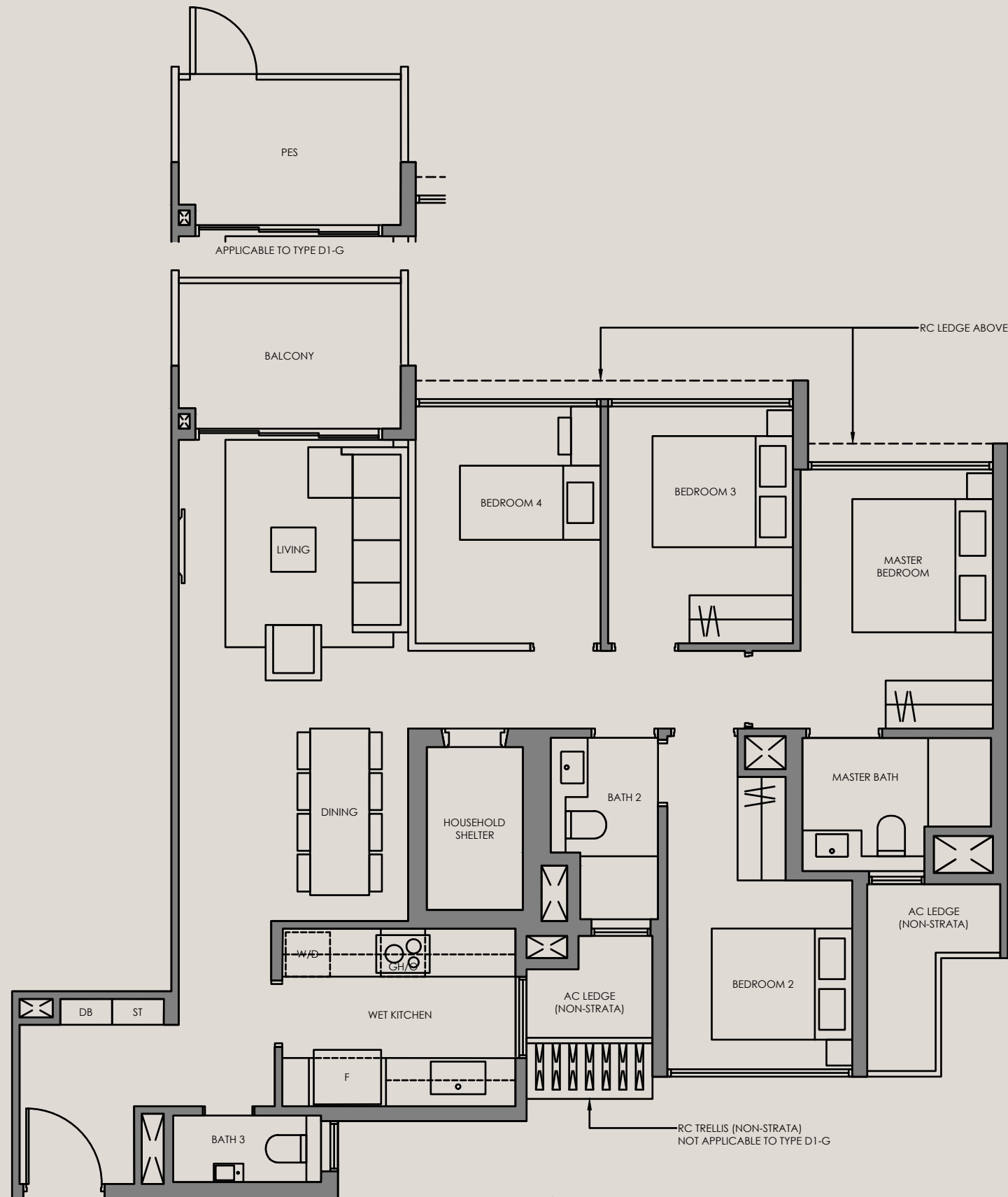

Legend (where applicable):

- F - Fridge
- P - Pantry
- O - Oven
- GH - Gas Hob
- IH - Induction Hob
- WD - Washer Dryer
- DB - Distribution Board
- ST - Store

*Mirror Image

ALL PLANS ARE SUBJECT TO AMENDMENTS AS MAY BE APPROVED BY THE RELEVANT AUTHORITIES. FLOOR AREAS ARE APPROXIMATE MEASUREMENTS AND ARE SUBJECT TO FINAL SURVEY.

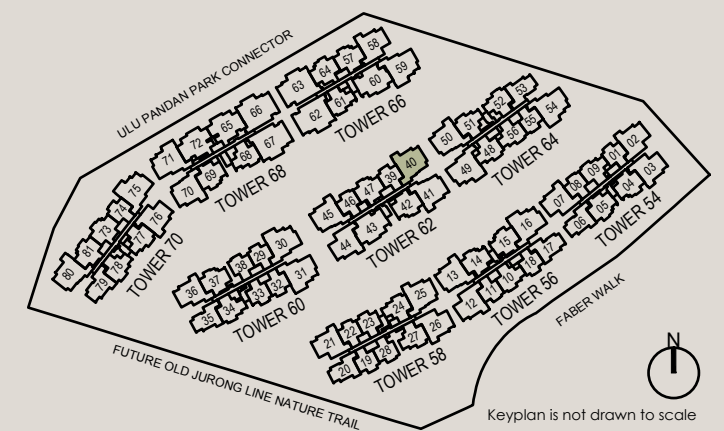
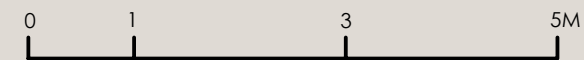

4-Bedroom

Type D2-G 104 SQM / 1119 SQFT
INCLUSIVE OF 6 SQM PES

TOWER	UNIT
58	#01-25
62	#01-45*
64	#01-50*
68	#01-70
70	#01-80*

Type D2 104 SQM / 1119 SQFT
INCLUSIVE OF 6 SQM BALCONY

TOWER	UNIT
58	#02-25 TO #05-25
62	#02-45* TO #05-45*
64	#02-50* TO #05-50*
68	#02-70 TO #05-70
70	#02-80* TO #05-80*



Legend (where applicable):

- F - Fridge
- IH - Induction Hob
- P - Pantry
- WD - Washer Dryer
- O - Oven
- DB - Distribution Board
- GH - Gas Hob
- ST - Store

*Mirror Image

ALL PLANS ARE SUBJECTED TO AMENDMENTS AS MAY BE APPROVED BY THE RELEVANT AUTHORITIES.
FLOOR AREAS ARE APPROXIMATE MEASUREMENTS AND ARE SUBJECTED TO FINAL SURVEY.

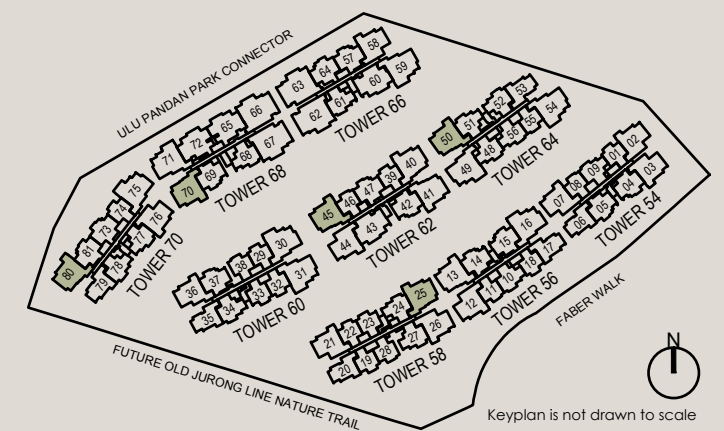
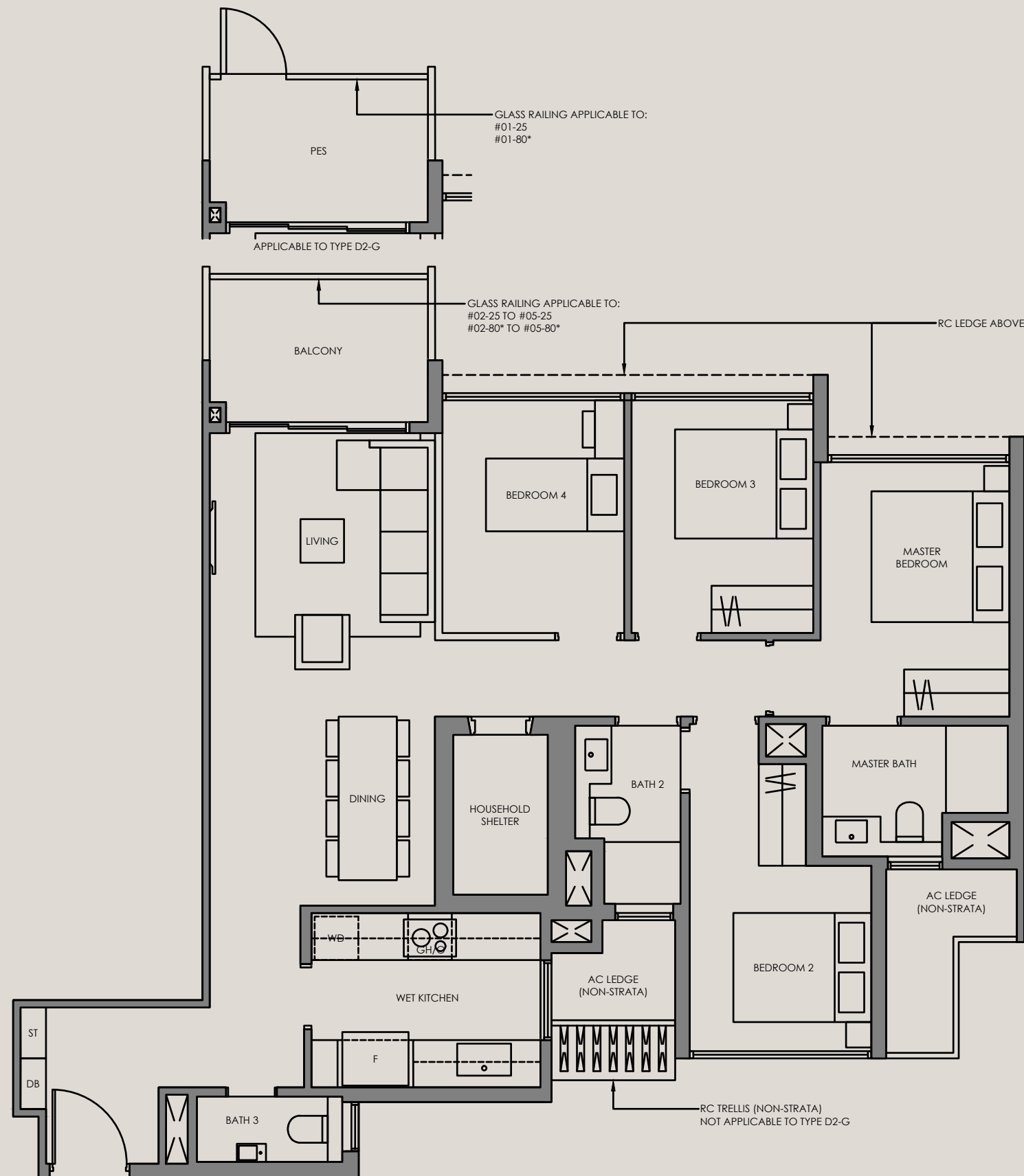

4-Bedroom

Type D3-G 104 SQM / 1119 SQFT
INCLUSIVE OF 6 SQM PES

TOWER	UNIT
56	#01-13
62	#01-41

Type D3 104 SQM / 1119 SQFT
INCLUSIVE OF 6 SQM BALCONY

TOWER	UNIT
56	#02-13 TO #05-13
62	#02-41 TO #05-41

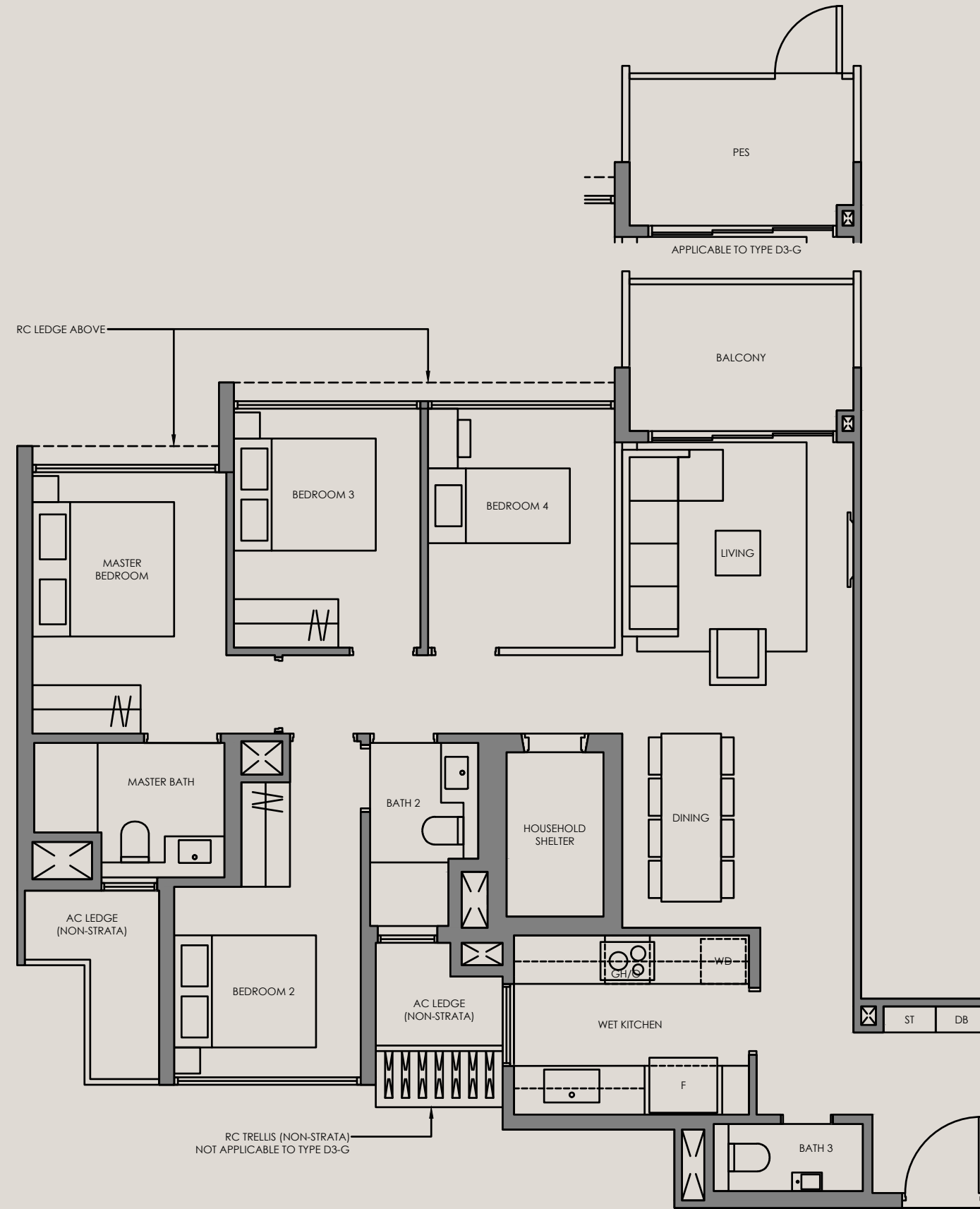

Legend (where applicable):

- F - Fridge
- P - Pantry
- O - Oven
- GH - Gas Hob
- IH - Induction Hob
- WD - Washer Dryer
- DB - Distribution Board
- ST - Store

*Mirror Image

ALL PLANS ARE SUBJECT TO AMENDMENTS AS MAY BE APPROVED BY THE RELEVANT AUTHORITIES.
FLOOR AREAS ARE APPROXIMATE MEASUREMENTS AND ARE SUBJECT TO FINAL SURVEY.

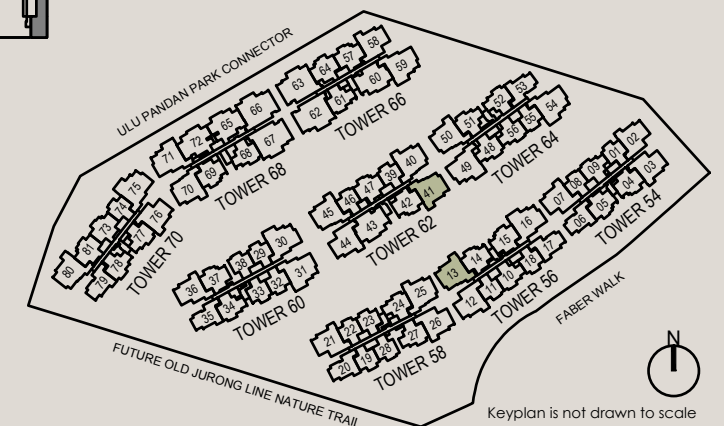
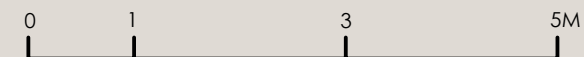

4-Bedroom

Type D4-G 112 SQM / 1206 SQFT
INCLUSIVE OF 9 SQM PES

TOWER	UNIT
62	#01-43
66	#01-60*

Type D4 112 SQM / 1206 SQFT
INCLUSIVE OF 9 SQM BALCONY

TOWER	UNIT
62	#02-43 TO #05-43
66	#02-60* TO #05-60*

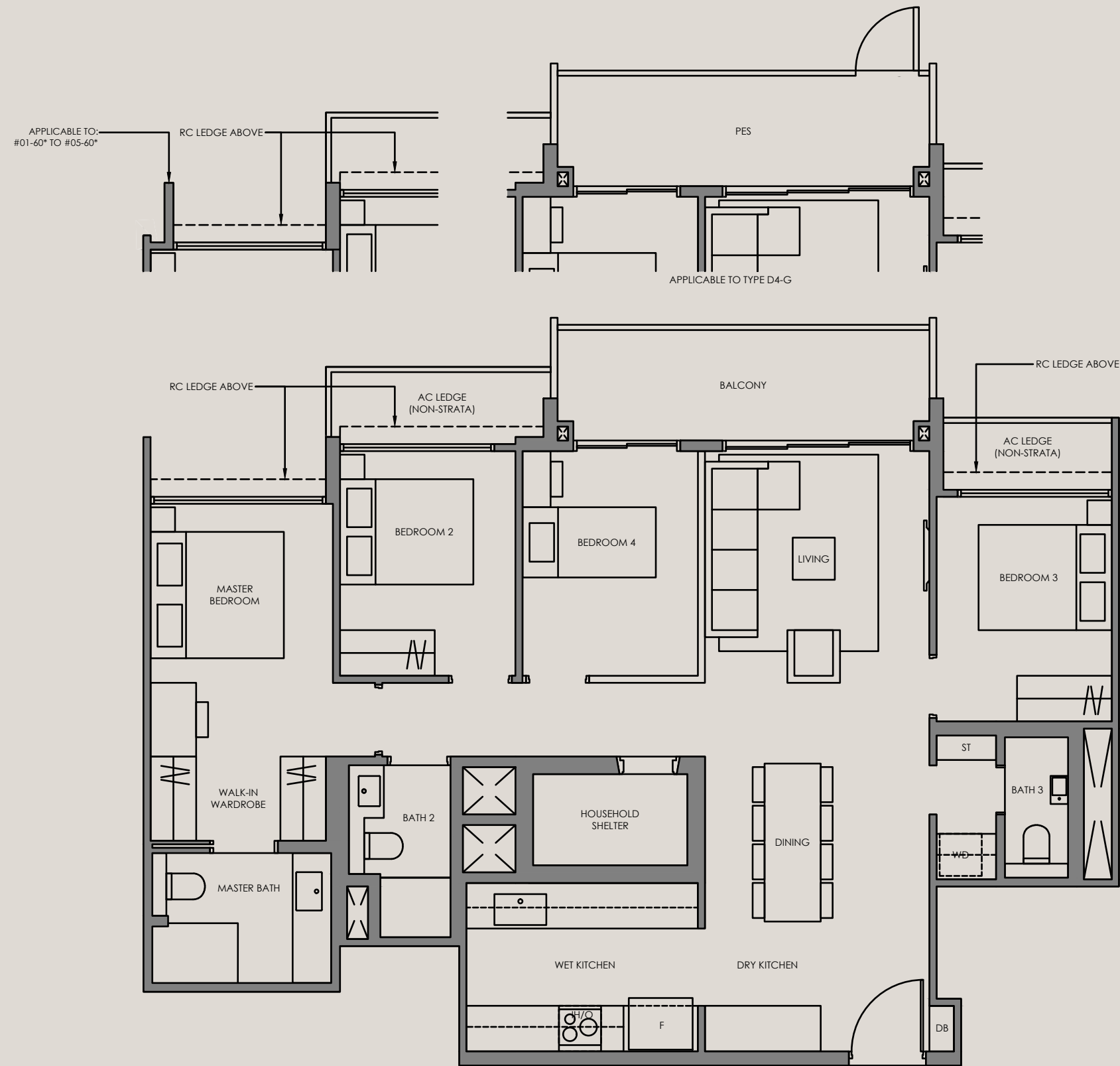

Legend (where applicable):

- F - Fridge
- P - Pantry
- O - Oven
- GH - Gas Hob
- IH - Induction Hob
- WD - Washer Dryer
- DB - Distribution Board
- ST - Store

*Mirror Image

ALL PLANS ARE SUBJECT TO AMENDMENTS AS MAY BE APPROVED BY THE RELEVANT AUTHORITIES. FLOOR AREAS ARE APPROXIMATE MEASUREMENTS AND ARE SUBJECT TO FINAL SURVEY.

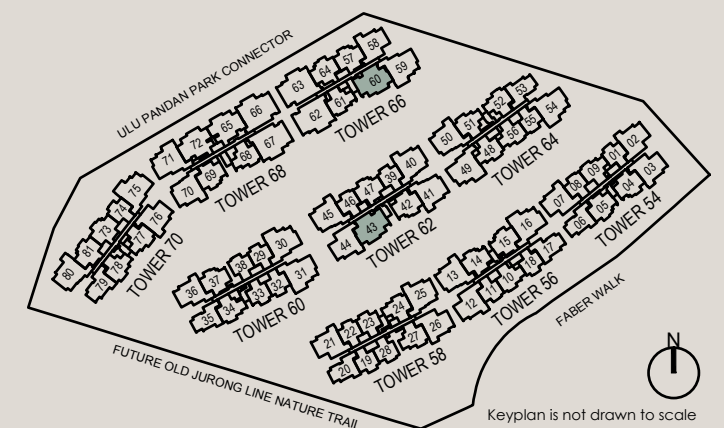
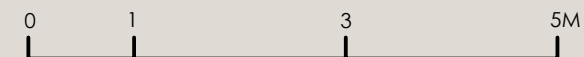

4-Bedroom

Type D5-G 113 SQM / 1216 SQFT
INCLUSIVE OF 9 SQM PES

TOWER 68
UNIT #01-65*
#01-72

Type D5 113 SQM / 1216 SQFT
INCLUSIVE OF 9 SQM BALCONY

TOWER 68
UNIT #02-65* TO #05-65*
#02-72 TO #05-72

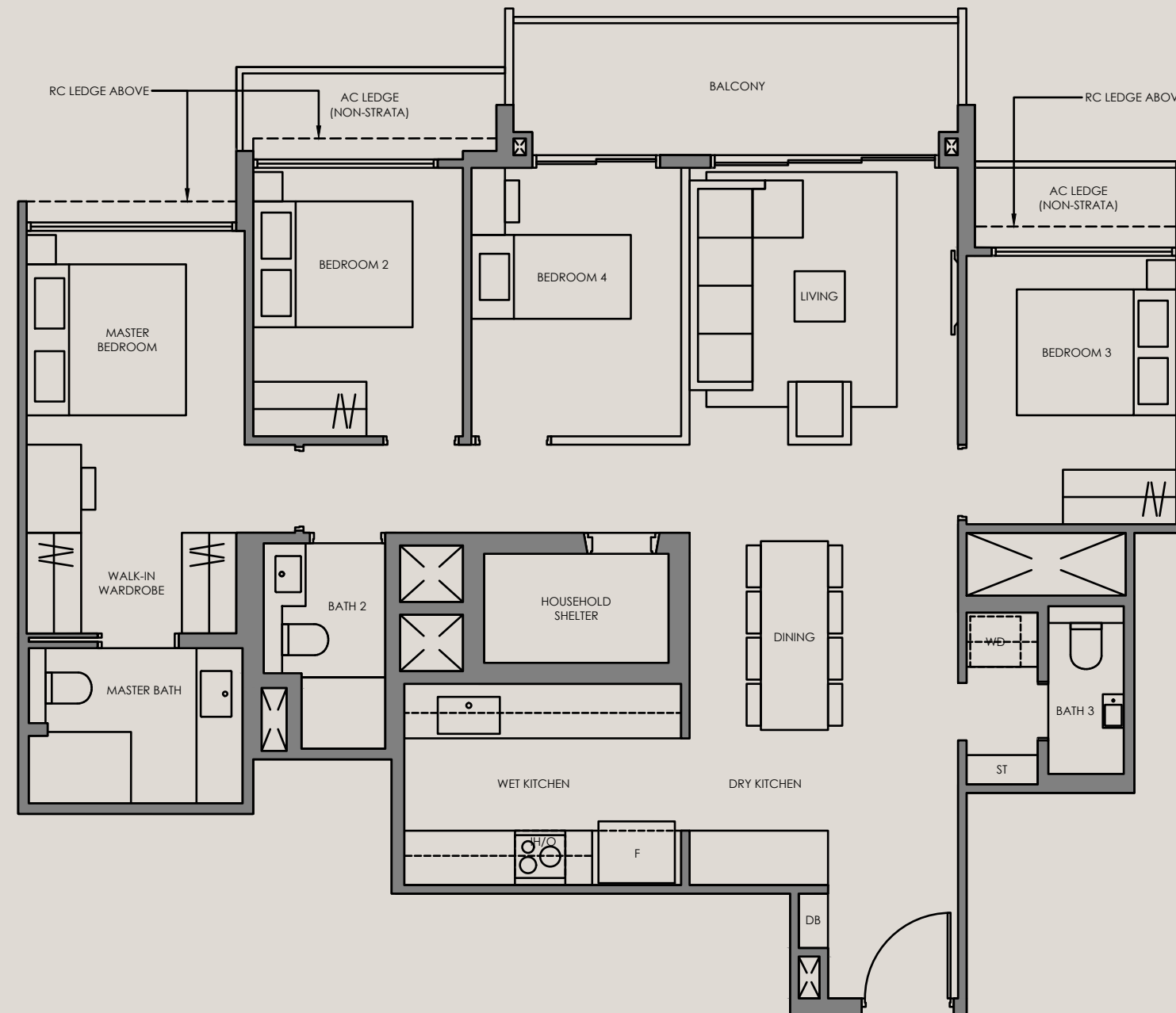
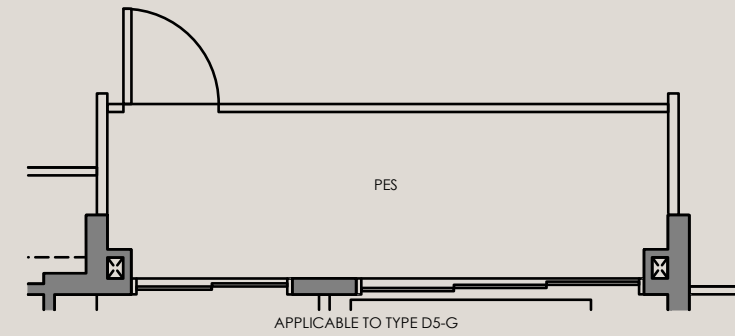

Legend (where applicable):

- F - Fridge
- P - Pantry
- O - Oven
- GH - Gas Hob
- IH - Induction Hob
- WD - Washer Dryer
- DB - Distribution Board
- ST - Store

*Mirror Image

ALL PLANS ARE SUBJECT TO AMENDMENTS AS MAY BE APPROVED BY THE RELEVANT AUTHORITIES.
FLOOR AREAS ARE APPROXIMATE MEASUREMENTS AND ARE SUBJECT TO FINAL SURVEY.

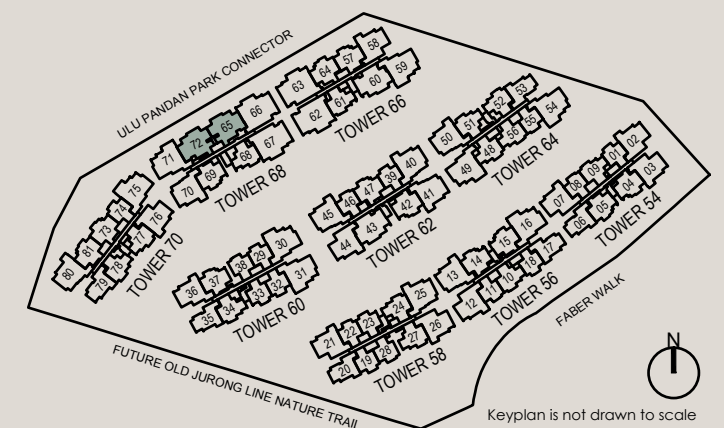
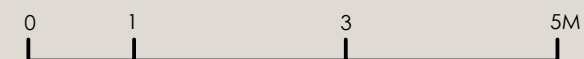

4-Bedroom

Type D6-G 118 SQM / 1270 SQFT
INCLUSIVE OF 9 SQM PES

TOWER	UNIT
60	#01-30 #01-31*
70	#01-75

Type D6 118 SQM / 1270 SQFT
INCLUSIVE OF 9 SQM BALCONY

TOWER	UNIT
60	#02-30 TO #05-30 #02-31* TO #05-31*
70	#02-75 TO #05-75

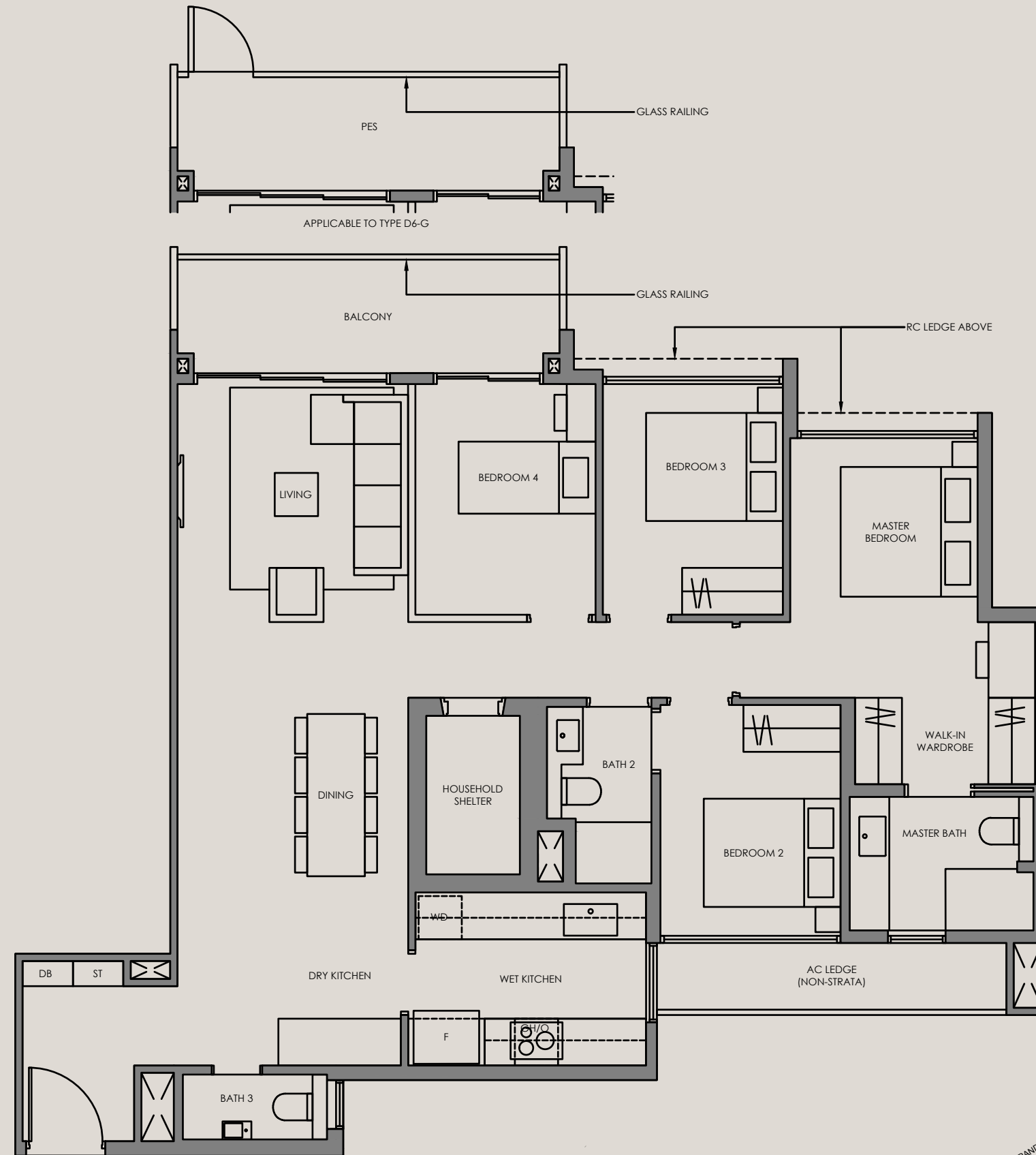

Legend (where applicable):

- F - Fridge
- P - Pantry
- O - Oven
- GH - Gas Hob
- IH - Induction Hob
- WD - Washer Dryer
- DB - Distribution Board
- ST - Store

*Mirror Image

ALL PLANS ARE SUBJECT TO AMENDMENTS AS MAY BE APPROVED BY THE RELEVANT AUTHORITIES.
FLOOR AREAS ARE APPROXIMATE MEASUREMENTS AND ARE SUBJECT TO FINAL SURVEY.

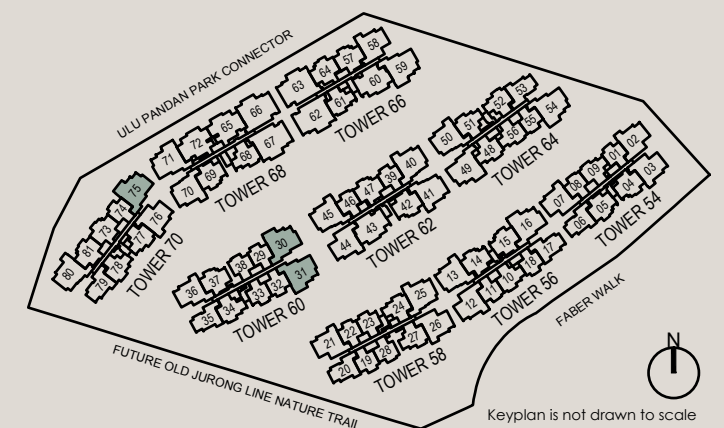
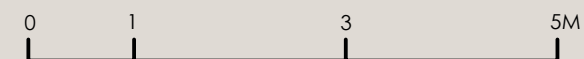

Keyplan is not drawn to scale

4-Bedroom

Type D7-G 118 SQM / 1270 SQFT
INCLUSIVE OF 9 SQM PES

TOWER	UNIT
64	#01-49
66	#01-59*

Type D7 118 SQM / 1270 SQFT
INCLUSIVE OF 9 SQM BALCONY

TOWER	UNIT
64	#02-49 TO #05-49
66	#02-59* TO #05-59*

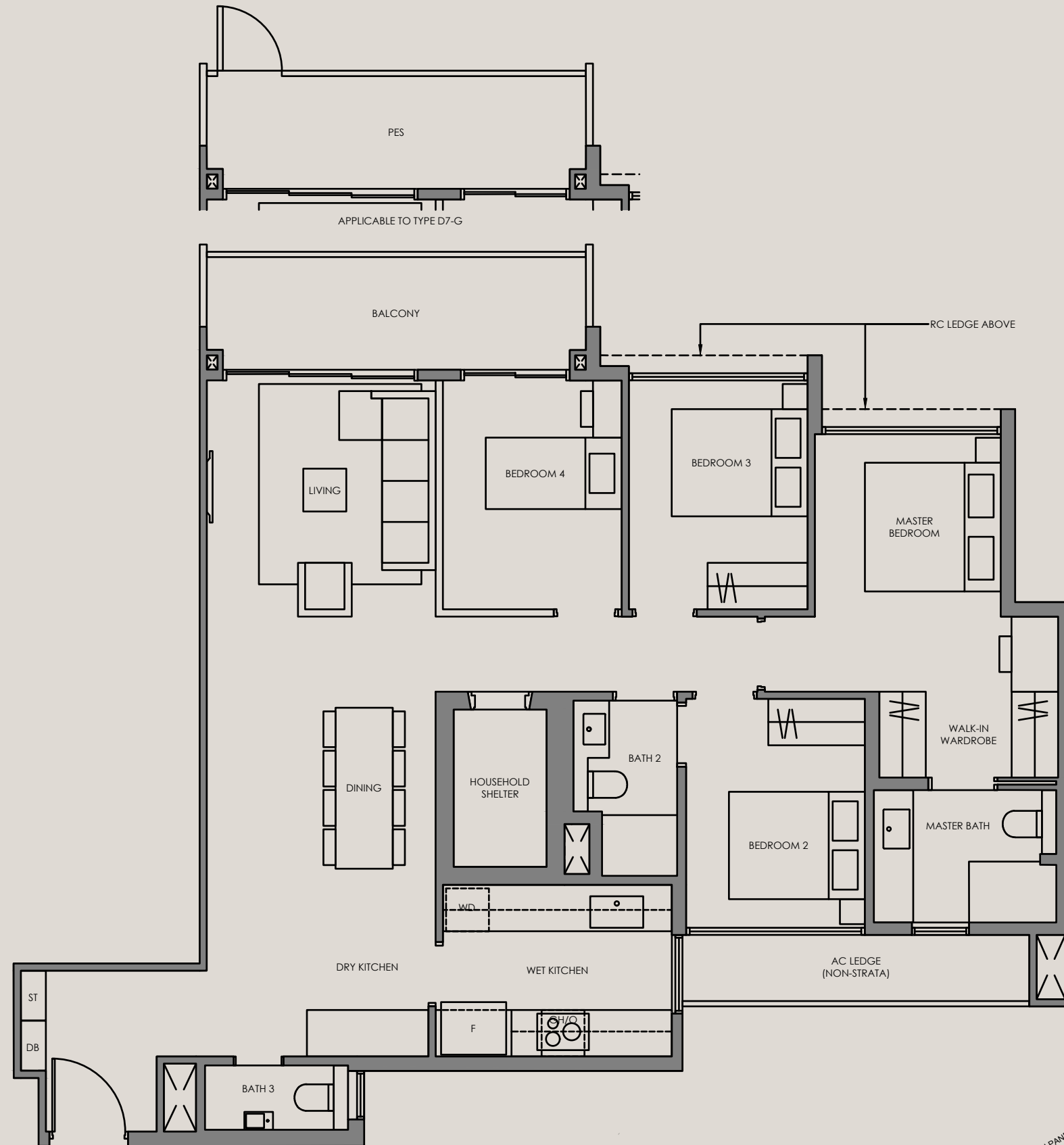

Legend (where applicable):

- F - Fridge
- P - Pantry
- O - Oven
- GH - Gas Hob
- IH - Induction Hob
- WD - Washer Dryer
- DB - Distribution Board
- ST - Store

*Mirror Image

ALL PLANS ARE SUBJECT TO AMENDMENTS AS MAY BE APPROVED BY THE RELEVANT AUTHORITIES.
FLOOR AREAS ARE APPROXIMATE MEASUREMENTS AND ARE SUBJECT TO FINAL SURVEY.

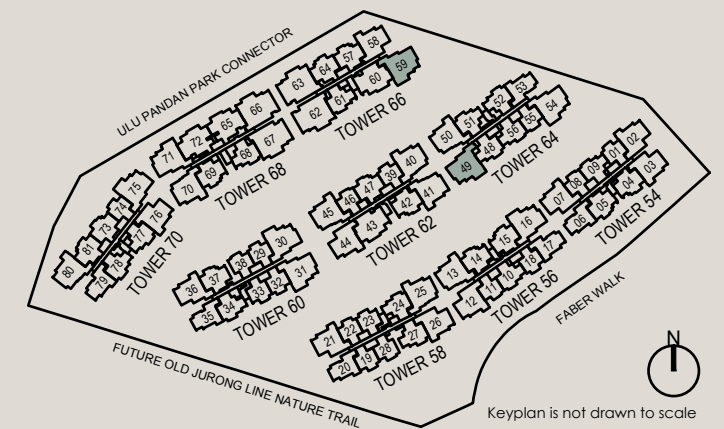

Keyplan is not drawn to scale

4-Bedroom

Type D8-G 118 SQM / 1270 SQFT
INCLUSIVE OF 9 SQM PES

TOWER	UNIT
56	#01-16
64	#01-54*
68	#01-71*

Type D8 118 SQM / 1270 SQFT
INCLUSIVE OF 9 SQM BALCONY

TOWER	UNIT
56	#02-16 TO #05-16
64	#02-54* TO #05-54*
68	#02-71* TO #05-71*

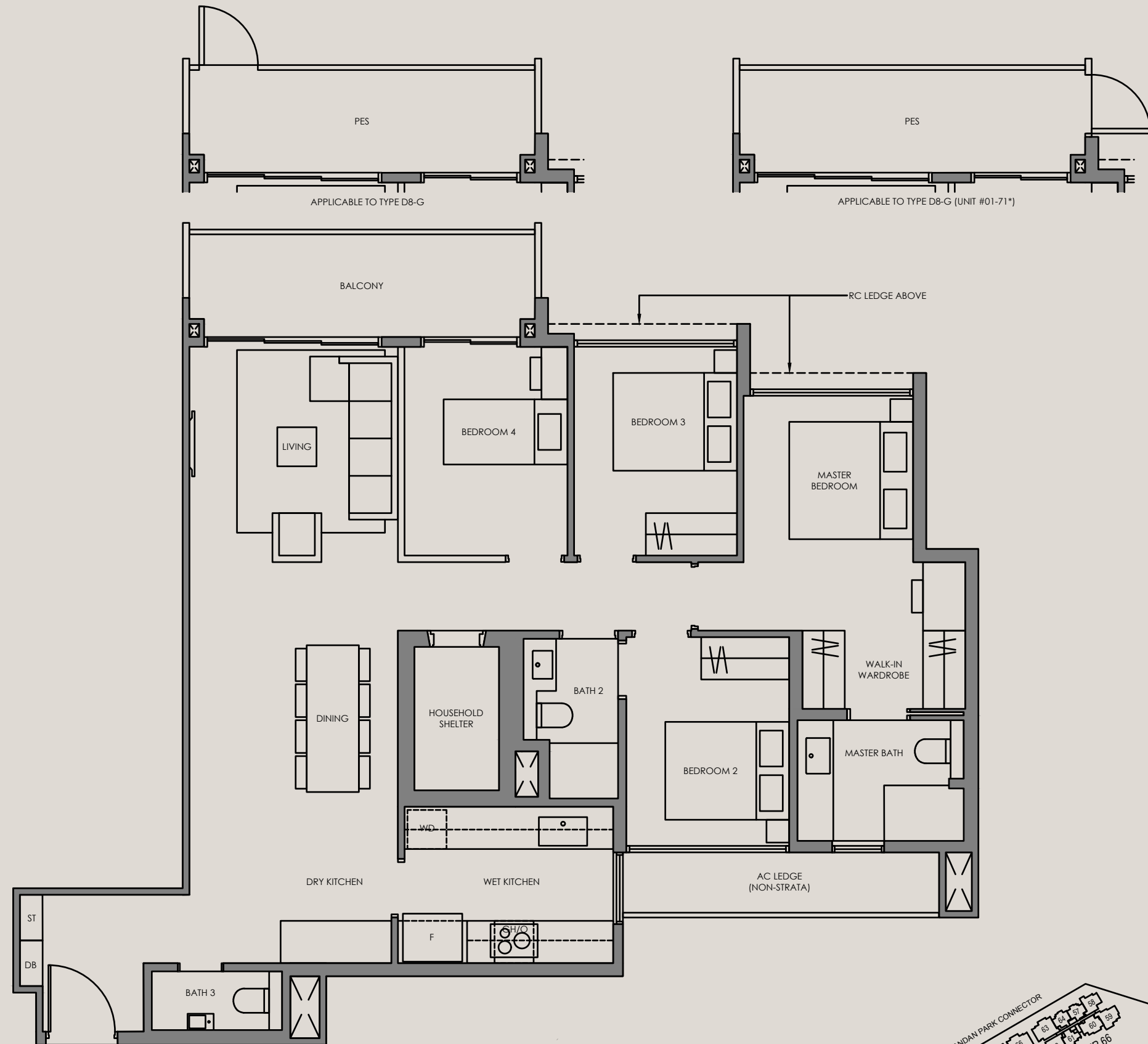

Legend (where applicable):

- F - Fridge
- P - Pantry
- O - Oven
- GH - Gas Hob
- IH - Induction Hob
- WD - Washer Dryer
- DB - Distribution Board
- ST - Store

*Mirror Image

ALL PLANS ARE SUBJECT TO AMENDMENTS AS MAY BE APPROVED BY THE RELEVANT AUTHORITIES. FLOOR AREAS ARE APPROXIMATE MEASUREMENTS AND ARE SUBJECT TO FINAL SURVEY.

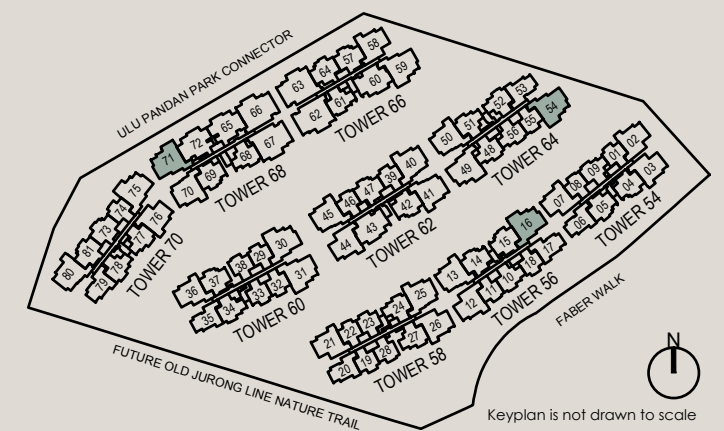

Keyplan is not drawn to scale

5-Bedroom

Type E1-G 138 SQM / 1485 SQFT
INCLUSIVE OF 10 SQM PES

TOWER	UNIT
66	#01-62* #01-63
68	#01-66* #01-67

Type E1 138 SQM / 1485 SQFT
INCLUSIVE OF 10 SQM BALCONY

TOWER	UNIT
66	#02-62* TO #05-62* #02-63 TO #05-63
68	#02-66* TO #05-66* #02-67 TO #05-67

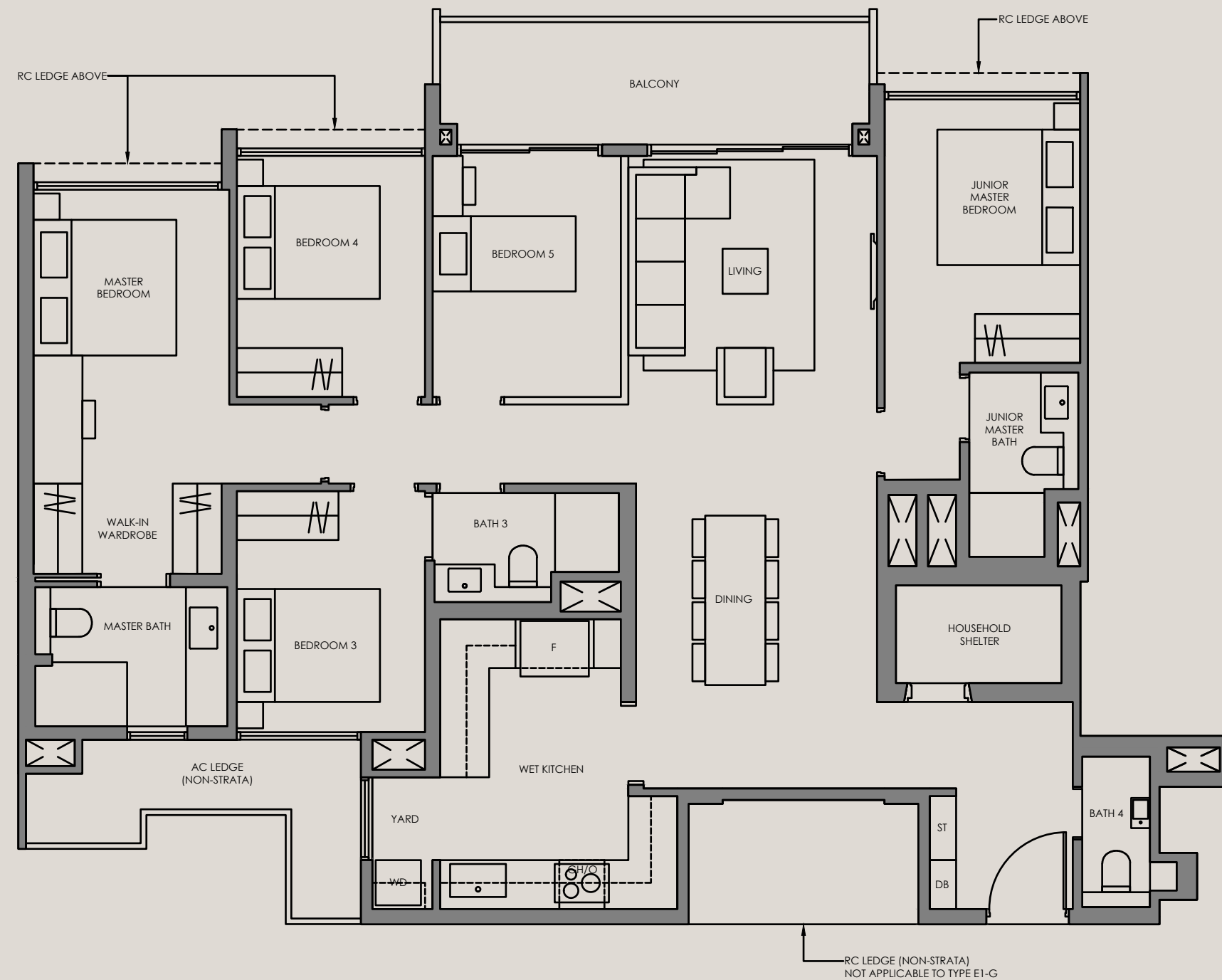
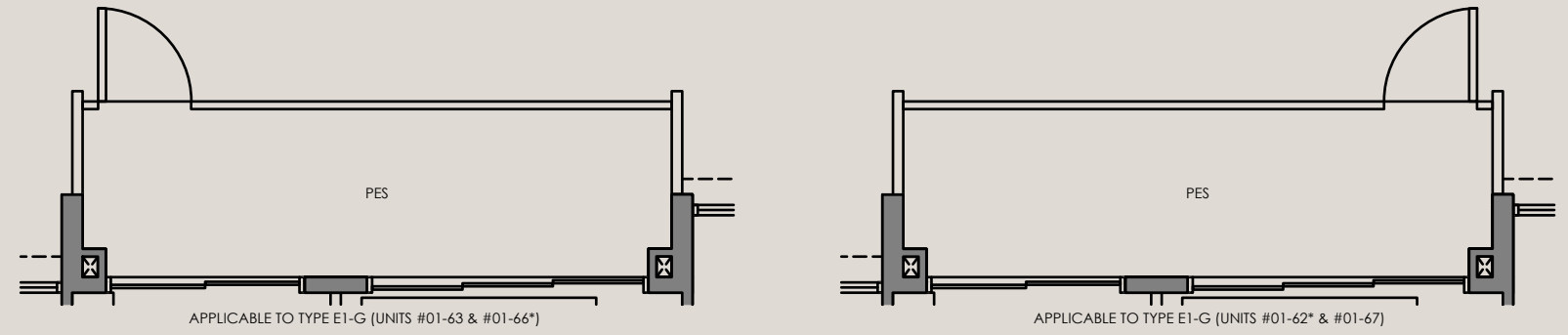

Legend (where applicable):

- F - Fridge
- P - Pantry
- O - Oven
- GH - Gas Hob
- IH - Induction Hob
- WD - Washer Dryer
- DB - Distribution Board
- ST - Store

*Mirror Image

ALL PLANS ARE SUBJECT TO AMENDMENTS AS MAY BE APPROVED BY THE RELEVANT AUTHORITIES.
FLOOR AREAS ARE APPROXIMATE MEASUREMENTS AND ARE SUBJECT TO FINAL SURVEY.

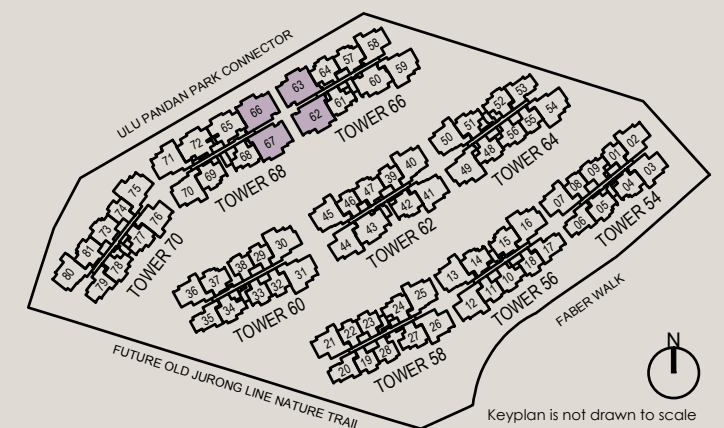
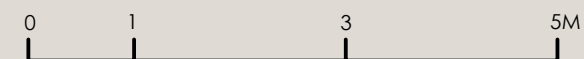

APPROVED BALCONY SCREEN

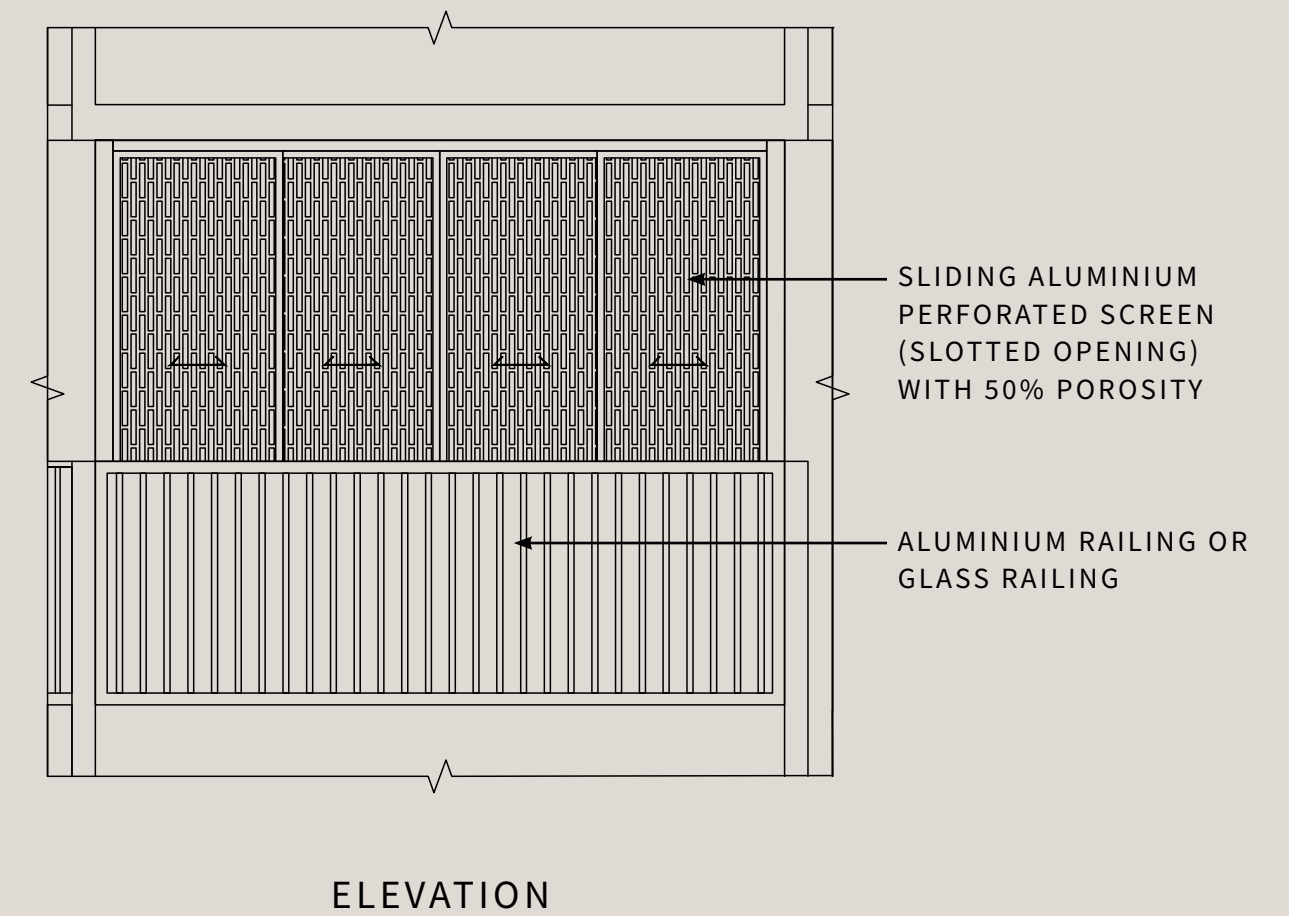
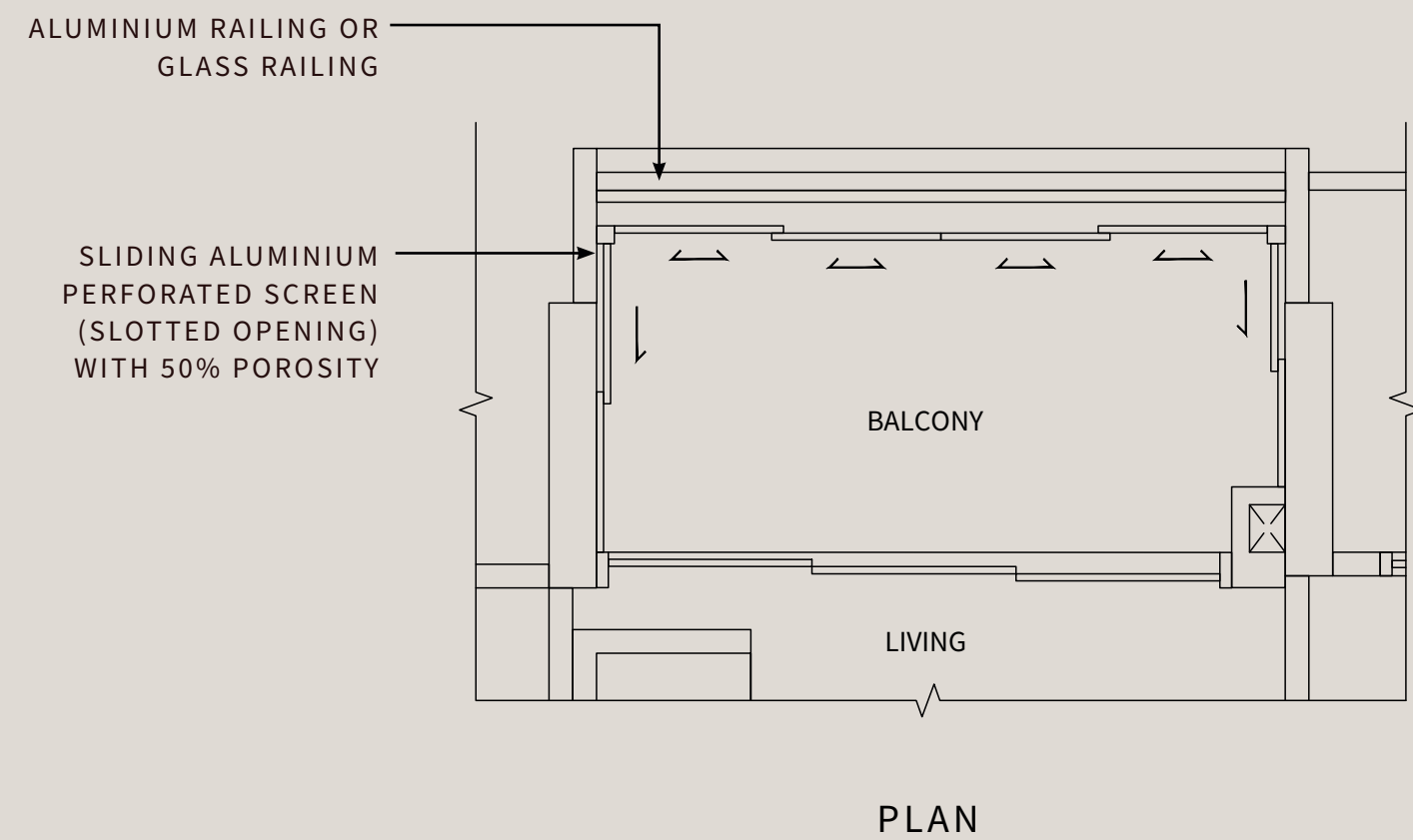

Note:

- 1 Approved balcony screen will not be provided and the purchaser to bear the cost for installing the balcony screen
- 2 The balcony shall not be enclosed unless with the approved balcony screen
- 3 Number of balcony screen panels varies according to different unit types
- 4 Hatching pattern is indicative
- 5 To refer to the approved balcony screen mock-up installed